

# 部 品

## N1 ~ N16

# N

部 品 他

N

部 品

テニアルガイダンス  
資



ねじ	N2
スプリング / カバー / カセット / 偏芯軸 / レバーピン / 押え金	N5
押え金	N6
ブレーカーピース / 敷板	N9
敷板	N10
敷板 / シート / サポート	N11
ロケーター / 止め輪 / ホース / コネクタ / O リング	N12
クーラントノズル / C 輪 / ワッシャー / ピン / ナット /	
引込みピン / アライメント治具 / スリーブ / 位置決め駒	N13
レンチ	N14
レンチ / 焼付防止剤	N15

### 在庫表示と記号

- 印：標準在庫品
- 印：将来、各頁記載の新製品による置換えを予定
- ▲印：将来、新製品に置換え・受注生産に移行・廃止などを予定  
(在庫を確認願います。)

- \*印：準標準在庫品 (在庫を確認願います。)
- 印：在庫予定品 (在庫を確認願います。)
- 無印：受注生産品
- ー印：製作いたしません



# ねじ

## ■ ねじ

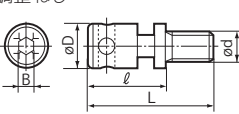
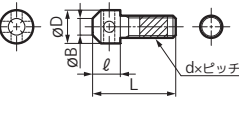
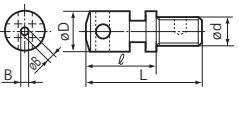
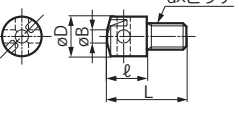
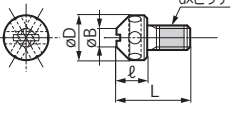
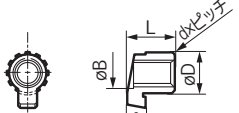
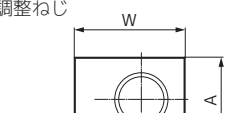
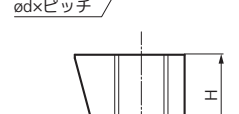
調整ねじ 	型番 <b>SRFJ</b>	在庫 ●	寸法 (mm)						N·m
			d	ピッチ	L	ℓ	D	B	
			M4	0.7	17	10.5	6	2	—
アキシャルアジャストスクリュー 	型番 <b>FMJ</b>	在庫 ●	寸法 (mm)						N·m
			d	ピッチ	L	ℓ	D	B	
			M4	0.5	15	5	6	3	—
アジャストボルト 	型番 <b>FMUJ</b>	在庫 ●	寸法 (mm)						N·m
			d	ピッチ	L	ℓ	D	B	
			M4	0.7	17	10.5	6	1	—
調整ねじ 	型番 <b>HFJ</b>	在庫 ●	寸法 (mm)						N·m
			d	ピッチ	L	ℓ	D	B	
			M4	0.7	12	6	6	2	—
アキシャルアジャストスクリュー 	型番 <b>AJM4FT</b>	在庫 ●	寸法 (mm)						N·m
			d	ピッチ	L	ℓ	D	B	
			M4	0.5	12	5	7.3	3	—
調整ねじ 	型番 <b>FME</b>	在庫 ●	寸法 (mm)						N·m
			d	ピッチ	L	ℓ	D	B	
			M7	0.75	13	5	11	8	—
調整ねじ 	型番 <b>BNRC-08</b> <b>BNRC-12</b> <b>BNRC-16</b> <b>BNRC-20</b>	在庫 ●	寸法 (mm)						N·m
			d	ピッチ	W	A	H	—	
			M5	0.8	10	6	6	—	—
			M5	0.8	11	10	8	—	—
			M8	1.25	16.5	12.5	12	—	—
			M8	1.25	16.5	16.5	12	—	—
調整楔 	型番 <b>FAAR</b>	在庫 ●	寸法 (mm)						N·m
			d	ピッチ	W	A	H	—	
			M8	0.75	10	12	6	—	—

## ■ ねじ

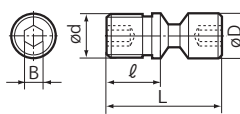
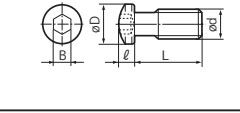
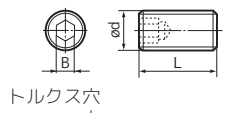
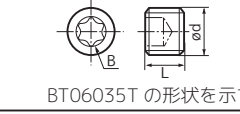
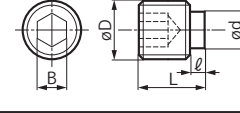
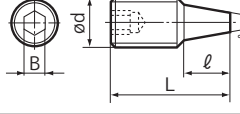
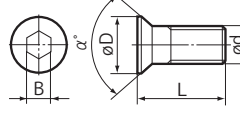
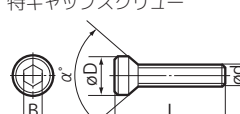
レバーロック用ボルト 	型番 <b>LCS3</b> <b>LCS4</b> <b>LCS5</b> <b>LCS6</b> <b>LCS4CA</b> <b>LCS8</b> <b>LCS10</b> <b>LCS12</b> <b>LCS16</b> <b>LCS20</b> <b>LCS25</b> <b>LCS32</b> <b>LCS3TE</b> <b>LCS33NT</b>	在庫 ●	寸法 (mm)						N·m
			d	ピッチ	L	ℓ	D	B	
			M6	1.0	17	10	6	2.5	—
			M8	1.0	21	10	8	3	—
			M8	1.0	25	12	8	3	—
			M10	1.0	27.2	14.4	9.8	4	—
			M8	1.0	17.5	10	8	3	—
			M12	1.0	36	18.3	11.8	5	—
			M5	0.8	14.5	8.5	5	2	—
			M6	1.0	17	9.6	6	2.5	—
			M6	1.0	21	13.6	6	2.5	—
			M8	1.0	23.5	13.2	8	3.0	—
			M10	1.0	30	17.4	10	4.0	—
			M12	1.0	36	19.3	12	5.0	—
			M6	1.0	15.5	8.5	6	2.5	—
			M5	0.8	12	6.2	—	2	—
ボタンねじ 	型番 <b>FBH0512</b> <b>FBX0811</b> <b>FBX0817</b>	在庫 ●	寸法 (mm)						N·m
			d	ピッチ	L	ℓ	D	B	
			M5	0.8	12	3.1	7.3	3	—
			M8	1.25	11.1	4.9	8.5	4	—
			M8	1.25	17.1	4.9	8.5	4	—
セットスクリュー 六角穴 	型番 <b>BT0306</b> <b>BT0404</b> <b>BT0406</b> <b>BT0408</b> <b>BT0506</b> <b>BT06035T</b>	在庫 ●	寸法 (mm)						N·m
			d	ピッチ	L	—	B	—	
			M3	0.5	6	—	1.5	—	
			M4	0.7	4	—	2	—	
			M4	0.7	6	—	2	—	
			M4	0.7	8	—	2	—	
			M5	0.8	6	—	2.5	—	
			M6	1.0	3.5	—	T15	—	
トルクス穴 	BT06035T の形状を示す								
セットスクリュー (棒先) 	型番 <b>BTD0809</b> <b>BTD1012</b>	在庫 ●	寸法 (mm)						N·m
			d	ピッチ	L	ℓ	D	B	
			M8	1.25	9	2	5	4	
			M10	1.5	12	2	8	5	
セットスクリュー 	型番 <b>BTT0407</b> <b>BTT0411</b>	在庫 ●	寸法 (mm)						N·m
			d	ピッチ	L	ℓ	—	B	
			M4	0.5	7	2.6	—	2	
			M4	0.5	11	2.6	—	2	
皿ねじ (六角穴) 	型番 <b>FBUP2-A0-8</b> <b>BFX0410R</b> <b>BFX0410L</b> <b>BFX0511R</b> <b>BFX0511L</b>	在庫 ●	寸法 (mm)						N·m
			d	ピッチ	L	D	B	α°	
			M3	0.5	10	5.5	2	82	
			M4	0.7	9.5	5.8	2.5	90	
			M4	0.7	9.5	5.8	2.5	90	
			M5	0.8	10.5	7.5	3	90	
			M5	0.8	10.5	7.5	3	90	
特キャップスクリュー 	型番 <b>BXF0520R</b> <b>BXF0616</b>	在庫 ●	寸法 (mm)						N·m
			d	ピッチ	L	D	B	α°	
			M5	0.8	25	8.5	4	90	
			M6	1.0	16	9	4	90	

部品他

N

部品

資材  
テニアルガイナス





# 押え金

部品他

N

部品

テフタルライナス  
資料

## ■ 押え金

	<table border="1"> <thead> <tr> <th rowspan="2">型番</th> <th rowspan="2">在庫</th> <th colspan="5">寸法 (mm)</th> <th rowspan="2">N-m</th> </tr> <tr> <th>W</th> <th>L</th> <th>d</th> <th>H</th> <th>—</th> </tr> </thead> <tbody> <tr> <td>MMW30</td> <td>●</td> <td>18</td> <td>16.6</td> <td>5.5</td> <td>8.9</td> <td>—</td> <td>—</td> </tr> <tr> <td>MMW40</td> <td>●</td> <td>24</td> <td>18</td> <td>6.5</td> <td>11</td> <td>—</td> <td>—</td> </tr> </tbody> </table>	型番	在庫	寸法 (mm)					N-m	W	L	d	H	—	MMW30	●	18	16.6	5.5	8.9	—	—	MMW40	●	24	18	6.5	11	—	—																																																
	型番			在庫	寸法 (mm)					N-m																																																																				
W		L	d		H	—																																																																								
MMW30	●	18	16.6	5.5	8.9	—	—																																																																							
MMW40	●	24	18	6.5	11	—	—																																																																							
	<table border="1"> <thead> <tr> <th rowspan="2">型番</th> <th rowspan="2">在庫</th> <th colspan="5">寸法 (mm)</th> <th rowspan="2">N-m</th> </tr> <tr> <th>W</th> <th>L</th> <th>d</th> <th>H</th> <th>B</th> </tr> </thead> <tbody> <tr> <td>MWW40</td> <td>●</td> <td>20</td> <td>19.15</td> <td>6.5</td> <td>10.8</td> <td>7.35</td> <td>—</td> </tr> </tbody> </table>	型番	在庫	寸法 (mm)					N-m	W	L	d	H	B	MWW40	●	20	19.15	6.5	10.8	7.35	—																																																								
	型番			在庫	寸法 (mm)					N-m																																																																				
W		L	d		H	B																																																																								
MWW40	●	20	19.15	6.5	10.8	7.35	—																																																																							
	<table border="1"> <thead> <tr> <th rowspan="2">型番</th> <th rowspan="2">在庫</th> <th colspan="5">寸法 (mm)</th> <th rowspan="2">N-m</th> </tr> <tr> <th>W</th> <th>L</th> <th>d</th> <th>H</th> <th>—</th> </tr> </thead> <tbody> <tr> <td>GDW600R</td> <td>●</td> <td>25</td> <td>32</td> <td>7</td> <td>15</td> <td>—</td> <td>—</td> </tr> <tr> <td>GDW600L</td> <td>●</td> <td>25</td> <td>32</td> <td>7</td> <td>15</td> <td>—</td> <td>—</td> </tr> <tr> <td>GDW615R</td> <td>●</td> <td>21</td> <td>37</td> <td>7</td> <td>15</td> <td>—</td> <td>—</td> </tr> <tr> <td>GDW615L</td> <td>●</td> <td>21</td> <td>37</td> <td>7</td> <td>15</td> <td>—</td> <td>—</td> </tr> <tr> <td>GDW800R</td> <td>●</td> <td>25</td> <td>32</td> <td>7</td> <td>15</td> <td>—</td> <td>—</td> </tr> <tr> <td>GDW800L</td> <td>●</td> <td>25</td> <td>32</td> <td>7</td> <td>15</td> <td>—</td> <td>—</td> </tr> <tr> <td>GDW815R</td> <td>●</td> <td>22.5</td> <td>37</td> <td>7</td> <td>15</td> <td>—</td> <td>—</td> </tr> <tr> <td>GDW815L</td> <td>●</td> <td>22.5</td> <td>37</td> <td>7</td> <td>15</td> <td>—</td> <td>—</td> </tr> </tbody> </table>	型番	在庫	寸法 (mm)					N-m	W	L	d	H	—	GDW600R	●	25	32	7	15	—	—	GDW600L	●	25	32	7	15	—	—	GDW615R	●	21	37	7	15	—	—	GDW615L	●	21	37	7	15	—	—	GDW800R	●	25	32	7	15	—	—	GDW800L	●	25	32	7	15	—	—	GDW815R	●	22.5	37	7	15	—	—	GDW815L	●	22.5	37	7	15	—	—
	型番			在庫	寸法 (mm)					N-m																																																																				
		W	L		d	H	—																																																																							
	GDW600R	●	25	32	7	15	—	—																																																																						
	GDW600L	●	25	32	7	15	—	—																																																																						
	GDW615R	●	21	37	7	15	—	—																																																																						
	GDW615L	●	21	37	7	15	—	—																																																																						
	GDW800R	●	25	32	7	15	—	—																																																																						
GDW800L	●	25	32	7	15	—	—																																																																							
GDW815R	●	22.5	37	7	15	—	—																																																																							
GDW815L	●	22.5	37	7	15	—	—																																																																							
	<table border="1"> <thead> <tr> <th rowspan="2">型番</th> <th rowspan="2">在庫</th> <th colspan="5">寸法 (mm)</th> <th rowspan="2">N-m</th> </tr> <tr> <th>W</th> <th>L</th> <th>d</th> <th>H</th> <th>—</th> </tr> </thead> <tbody> <tr> <td>GDW645R</td> <td>●</td> <td>30</td> <td>31.2</td> <td>7</td> <td>15</td> <td>—</td> <td>—</td> </tr> <tr> <td>GDW645L</td> <td>●</td> <td>30</td> <td>31.2</td> <td>7</td> <td>15</td> <td>—</td> <td>—</td> </tr> <tr> <td>GDW845R</td> <td>●</td> <td>30</td> <td>28</td> <td>7</td> <td>15</td> <td>—</td> <td>—</td> </tr> <tr> <td>GDW845L</td> <td>●</td> <td>30</td> <td>28</td> <td>7</td> <td>15</td> <td>—</td> <td>—</td> </tr> </tbody> </table>	型番	在庫	寸法 (mm)					N-m	W	L	d	H	—	GDW645R	●	30	31.2	7	15	—	—	GDW645L	●	30	31.2	7	15	—	—	GDW845R	●	30	28	7	15	—	—	GDW845L	●	30	28	7	15	—	—																																
	型番			在庫	寸法 (mm)					N-m																																																																				
		W	L		d	H	—																																																																							
	GDW645R	●	30	31.2	7	15	—	—																																																																						
GDW645L	●	30	31.2	7	15	—	—																																																																							
GDW845R	●	30	28	7	15	—	—																																																																							
GDW845L	●	30	28	7	15	—	—																																																																							
	<table border="1"> <thead> <tr> <th rowspan="2">型番</th> <th rowspan="2">在庫</th> <th colspan="5">寸法 (mm)</th> <th rowspan="2">N-m</th> </tr> <tr> <th>W</th> <th>L</th> <th>d</th> <th>H</th> <th>—</th> </tr> </thead> <tbody> <tr> <td>GDS600R</td> <td>●</td> <td>25</td> <td>32</td> <td>7</td> <td>15</td> <td>—</td> <td>—</td> </tr> <tr> <td>GDS600L</td> <td>●</td> <td>25</td> <td>32</td> <td>7</td> <td>15</td> <td>—</td> <td>—</td> </tr> <tr> <td>GDS615R</td> <td>●</td> <td>21</td> <td>37</td> <td>7</td> <td>15</td> <td>—</td> <td>—</td> </tr> <tr> <td>GDS615L</td> <td>●</td> <td>21</td> <td>37</td> <td>7</td> <td>15</td> <td>—</td> <td>—</td> </tr> <tr> <td>GDS800R</td> <td>●</td> <td>25</td> <td>32</td> <td>7</td> <td>15</td> <td>—</td> <td>—</td> </tr> <tr> <td>GDS800L</td> <td>●</td> <td>25</td> <td>32</td> <td>7</td> <td>15</td> <td>—</td> <td>—</td> </tr> <tr> <td>GDS815R</td> <td>●</td> <td>22.5</td> <td>37</td> <td>7</td> <td>15</td> <td>—</td> <td>—</td> </tr> <tr> <td>GDS815L</td> <td>●</td> <td>22.5</td> <td>37</td> <td>7</td> <td>15</td> <td>—</td> <td>—</td> </tr> </tbody> </table>	型番	在庫	寸法 (mm)					N-m	W	L	d	H	—	GDS600R	●	25	32	7	15	—	—	GDS600L	●	25	32	7	15	—	—	GDS615R	●	21	37	7	15	—	—	GDS615L	●	21	37	7	15	—	—	GDS800R	●	25	32	7	15	—	—	GDS800L	●	25	32	7	15	—	—	GDS815R	●	22.5	37	7	15	—	—	GDS815L	●	22.5	37	7	15	—	—
	型番			在庫	寸法 (mm)					N-m																																																																				
		W	L		d	H	—																																																																							
	GDS600R	●	25	32	7	15	—	—																																																																						
	GDS600L	●	25	32	7	15	—	—																																																																						
	GDS615R	●	21	37	7	15	—	—																																																																						
	GDS615L	●	21	37	7	15	—	—																																																																						
GDS800R	●	25	32	7	15	—	—																																																																							
GDS800L	●	25	32	7	15	—	—																																																																							
GDS815R	●	22.5	37	7	15	—	—																																																																							
GDS815L	●	22.5	37	7	15	—	—																																																																							
	<table border="1"> <thead> <tr> <th rowspan="2">型番</th> <th rowspan="2">在庫</th> <th colspan="5">寸法 (mm)</th> <th rowspan="2">N-m</th> </tr> <tr> <th>W</th> <th>L</th> <th>d</th> <th>H</th> <th>—</th> </tr> </thead> <tbody> <tr> <td>GDS645R</td> <td>●</td> <td>30</td> <td>31.2</td> <td>7</td> <td>15</td> <td>—</td> <td>—</td> </tr> <tr> <td>GDS645L</td> <td>●</td> <td>30</td> <td>31.2</td> <td>7</td> <td>15</td> <td>—</td> <td>—</td> </tr> <tr> <td>GDS845R</td> <td>●</td> <td>30</td> <td>28</td> <td>7</td> <td>15</td> <td>—</td> <td>—</td> </tr> <tr> <td>GDS845L</td> <td>●</td> <td>30</td> <td>28</td> <td>7</td> <td>15</td> <td>—</td> <td>—</td> </tr> </tbody> </table>	型番	在庫	寸法 (mm)					N-m	W	L	d	H	—	GDS645R	●	30	31.2	7	15	—	—	GDS645L	●	30	31.2	7	15	—	—	GDS845R	●	30	28	7	15	—	—	GDS845L	●	30	28	7	15	—	—																																
	型番			在庫	寸法 (mm)					N-m																																																																				
		W	L		d	H	—																																																																							
	GDS645R	●	30	31.2	7	15	—	—																																																																						
GDS645L	●	30	31.2	7	15	—	—																																																																							
GDS845R	●	30	28	7	15	—	—																																																																							
GDS845L	●	30	28	7	15	—	—																																																																							

## ■ 押え金

	<table border="1"> <thead> <tr> <th rowspan="2">型番</th> <th rowspan="2">在庫</th> <th colspan="5">寸法 (mm)</th> <th rowspan="2">N-m</th> </tr> <tr> <th>W</th> <th>L</th> <th>d</th> <th>ピッチ</th> <th>H</th> </tr> </thead> <tbody> <tr> <td>CCM8-LONG</td> <td>●</td> <td>11</td> <td>24</td> <td>M8</td> <td>1.25</td> <td>17</td> <td>—</td> </tr> </tbody> </table>	型番	在庫	寸法 (mm)					N-m	W	L	d	ピッチ	H	CCM8-LONG	●	11	24	M8	1.25	17	—																																								
	型番			在庫	寸法 (mm)					N-m																																																				
W		L	d		ピッチ	H																																																								
CCM8-LONG	●	11	24	M8	1.25	17	—																																																							
	<table border="1"> <thead> <tr> <th rowspan="2">型番</th> <th rowspan="2">在庫</th> <th colspan="5">寸法 (mm)</th> <th rowspan="2">N-m</th> </tr> <tr> <th>d</th> <th>ピッチ</th> <th>W</th> <th>L</th> <th>H</th> </tr> </thead> <tbody> <tr> <td>CCM6BR</td> <td>●</td> <td>M6</td> <td>1.0</td> <td>8.8</td> <td>16.5</td> <td>7</td> <td>—</td> </tr> <tr> <td>CCM6BL</td> <td>●</td> <td>M6</td> <td>1.0</td> <td>8.8</td> <td>16.5</td> <td>7</td> <td>—</td> </tr> <tr> <td>CCM5BSR</td> <td>●</td> <td>M5</td> <td>0.8</td> <td>6.8</td> <td>14</td> <td>7</td> <td>—</td> </tr> <tr> <td>CCM5BSL</td> <td>●</td> <td>M5</td> <td>0.8</td> <td>6.8</td> <td>14</td> <td>7</td> <td>—</td> </tr> <tr> <td>CCM6UL</td> <td>●</td> <td>M6</td> <td>1.0</td> <td>8.8</td> <td>17.5</td> <td>8</td> <td>—</td> </tr> <tr> <td>CCM8UR</td> <td>●</td> <td>M8</td> <td>1.25</td> <td>12</td> <td>21</td> <td>8</td> <td>—</td> </tr> </tbody> </table>	型番	在庫	寸法 (mm)					N-m	d	ピッチ	W	L	H	CCM6BR	●	M6	1.0	8.8	16.5	7	—	CCM6BL	●	M6	1.0	8.8	16.5	7	—	CCM5BSR	●	M5	0.8	6.8	14	7	—	CCM5BSL	●	M5	0.8	6.8	14	7	—	CCM6UL	●	M6	1.0	8.8	17.5	8	—	CCM8UR	●	M8	1.25	12	21	8	—
	型番			在庫	寸法 (mm)					N-m																																																				
		d	ピッチ		W	L	H																																																							
	CCM6BR	●	M6	1.0	8.8	16.5	7	—																																																						
	CCM6BL	●	M6	1.0	8.8	16.5	7	—																																																						
	CCM5BSR	●	M5	0.8	6.8	14	7	—																																																						
CCM5BSL	●	M5	0.8	6.8	14	7	—																																																							
CCM6UL	●	M6	1.0	8.8	17.5	8	—																																																							
CCM8UR	●	M8	1.25	12	21	8	—																																																							
	<table border="1"> <thead> <tr> <th rowspan="2">型番</th> <th rowspan="2">在庫</th> <th colspan="5">寸法 (mm)</th> <th rowspan="2">N-m</th> </tr> <tr> <th>d</th> <th>ピッチ</th> <th>D</th> <th>H</th> <th>—</th> </tr> </thead> <tbody> <tr> <td>BWS30</td> <td>●</td> <td>M8</td> <td>1.25</td> <td>9</td> <td>11.2</td> <td>—</td> <td>—</td> </tr> </tbody> </table>	型番	在庫	寸法 (mm)					N-m	d	ピッチ	D	H	—	BWS30	●	M8	1.25	9	11.2	—	—																																								
	型番			在庫	寸法 (mm)					N-m																																																				
d		ピッチ	D		H	—																																																								
BWS30	●	M8	1.25	9	11.2	—	—																																																							
	<table border="1"> <thead> <tr> <th rowspan="2">型番</th> <th rowspan="2">在庫</th> <th colspan="5">寸法 (mm)</th> <th rowspan="2">N-m</th> </tr> <tr> <th>L</th> <th>D</th> <th>—</th> <th>—</th> <th>—</th> </tr> </thead> <tbody> <tr> <td>CKBW16</td> <td>●</td> <td>9.6</td> <td>7.2</td> <td>—</td> <td>—</td> <td>—</td> <td>—</td> </tr> </tbody> </table>	型番	在庫	寸法 (mm)					N-m	L	D	—	—	—	CKBW16	●	9.6	7.2	—	—	—	—																																								
	型番			在庫	寸法 (mm)					N-m																																																				
L		D	—		—	—																																																								
CKBW16	●	9.6	7.2	—	—	—	—																																																							
	<table border="1"> <thead> <tr> <th rowspan="2">型番</th> <th rowspan="2">在庫</th> <th colspan="5">寸法 (mm)</th> <th rowspan="2">N-m</th> </tr> <tr> <th>T</th> <th>d</th> <th>D</th> <th>H</th> <th>—</th> </tr> </thead> <tbody> <tr> <td>BNGCR</td> <td>●</td> <td>9.88</td> <td>7</td> <td>11</td> <td>24</td> <td>—</td> <td>—</td> </tr> <tr> <td>BNGCL</td> <td>●</td> <td>9.88</td> <td>7</td> <td>11</td> <td>24</td> <td>—</td> <td>—</td> </tr> </tbody> </table>	型番	在庫	寸法 (mm)					N-m	T	d	D	H	—	BNGCR	●	9.88	7	11	24	—	—	BNGCL	●	9.88	7	11	24	—	—																																
	型番			在庫	寸法 (mm)					N-m																																																				
T		d	D		H	—																																																								
BNGCR	●	9.88	7	11	24	—	—																																																							
BNGCL	●	9.88	7	11	24	—	—																																																							
	<table border="1"> <thead> <tr> <th rowspan="2">型番</th> <th rowspan="2">在庫</th> <th colspan="5">寸法 (mm)</th> <th rowspan="2">N-m</th> </tr> <tr> <th>W</th> <th>L</th> <th>d</th> <th>D</th> <th>H</th> </tr> </thead> <tbody> <tr> <td>BNBC</td> <td>●</td> <td>6.3</td> <td>11</td> <td>3</td> <td>5.7</td> <td>3.4</td> <td>—</td> </tr> </tbody> </table>	型番	在庫	寸法 (mm)					N-m	W	L	d	D	H	BNBC	●	6.3	11	3	5.7	3.4	—																																								
	型番			在庫	寸法 (mm)					N-m																																																				
W		L	d		D	H																																																								
BNBC	●	6.3	11	3	5.7	3.4	—																																																							
	<table border="1"> <thead> <tr> <th rowspan="2">型番</th> <th rowspan="2">在庫</th> <th colspan="5">寸法 (mm)</th> <th rowspan="2">N-m</th> </tr> <tr> <th>T</th> <th>d</th> <th>D</th> <th>h</th> <th>H</th> </tr> </thead> <tbody> <tr> <td>GCLR-3</td> <td>●</td> <td>6.3</td> <td>5.3</td> <td>9</td> <td>2</td> <td>15</td> <td>—</td> </tr> <tr> <td>GCLL-3</td> <td>●</td> <td>6.3</td> <td>5.3</td> <td>9</td> <td>2</td> <td>15</td> <td>—</td> </tr> <tr> <td>GCLR-4</td> <td>●</td> <td>6.3</td> <td>5.3</td> <td>9</td> <td>3</td> <td>15</td> <td>—</td> </tr> <tr> <td>GCLL-4</td> <td>●</td> <td>6.3</td> <td>5.3</td> <td>9</td> <td>3</td> <td>15</td> <td>—</td> </tr> <tr> <td>GCLR-6</td> <td>●</td> <td>6.3</td> <td>5.3</td> <td>9</td> <td>5</td> <td>18</td> <td>—</td> </tr> <tr> <td>GCLL-6</td> <td>●</td> <td>6.3</td> <td>5.3</td> <td>9</td> <td>5</td> <td>18</td> <td>—</td> </tr> </tbody> </table>	型番	在庫	寸法 (mm)					N-m	T	d	D	h	H	GCLR-3	●	6.3	5.3	9	2	15	—	GCLL-3	●	6.3	5.3	9	2	15	—	GCLR-4	●	6.3	5.3	9	3	15	—	GCLL-4	●	6.3	5.3	9	3	15	—	GCLR-6	●	6.3	5.3	9	5	18	—	GCLL-6	●	6.3	5.3	9	5	18	—
	型番			在庫	寸法 (mm)					N-m																																																				
		T	d		D	h	H																																																							
	GCLR-3	●	6.3	5.3	9	2	15	—																																																						
	GCLL-3	●	6.3	5.3	9	2	15	—																																																						
	GCLR-4	●	6.3	5.3	9	3	15	—																																																						
GCLL-4	●	6.3	5.3	9	3	15	—																																																							
GCLR-6	●	6.3	5.3	9	5	18	—																																																							
GCLL-6	●	6.3	5.3	9	5	18	—																																																							

# 押え金

## ■ 押え金

	型番	在庫	寸法 (mm)					
	GTCR	●	30.4	8.7	14.3	18.6	—	
GTCL	●	30.4	8.7	14.3	18.6	—	—	
※: 左ねじを示す								
	型番	在庫	寸法 (mm)					
	UFKWR	●	10	M7	1	10.54	—	
UFKWL	●	10	M7	1	10.54	—	—	
※: 左ねじを示す								
	型番	在庫	寸法 (mm)					
	UFTWR	●	10	M7	1	11.3	—	
UFTWL	●	10	M7	1	11.3	—	—	
※: 左ねじを示す								
	型番	在庫	寸法 (mm)					
	GRWR	●	30.4	M8	1.25	13	—	
GRWL	●	30.4	M8	1.25	13	—	—	
※: 左ねじを示す								
	型番	在庫	寸法 (mm)					
	FPWR	●	15	5.2	16	—	—	
	FPWL	●	15	5.2	16	—	—	
	FEWR	●	15	5.2	15	—	—	
FEWL	●	15	5.2	15	—	—	—	
※: 左ねじを示す								
	型番	在庫	寸法 (mm)					
	EHW4R	●	22	13.5	5.65	6.15	14.6	
EHW5R	●	25	13.5	5.6	5.6	14.6	—	
※: 左ねじを示す								
	型番	在庫	寸法 (mm)					
	FTW40R	●	17	M8	1.25	12.85	—	
FTW40L	●	17	M8	1.25	12.85	—	—	
※: 左ねじを示す								
	型番	在庫	寸法 (mm)					
	FTW41R	●	17	M8	1.25	12.85	—	
FTW41L	●	17	M8	1.25	12.85	—	—	
※: 左ねじを示す								
	型番	在庫	寸法 (mm)					
	ATW45R	●	14	M8	1.25	17.9	—	
ATW45L	●	14	M8	1.25	17.9	—	—	
※: 左ねじを示す								

## ■ 押え金

	型番	在庫	寸法 (mm)						
	BCS15	●	74	7	11	14	17		—
	BCS20	●	90	7	11	15.5	17		—
BCS25	●	100	7	11	15.5	17	—	—	
※: 左ねじを示す									
	型番	在庫	寸法 (mm)						
	GLW40R	●	18.5	M8	1.25	16.1	—		—
	GLW40L	●	18.5	M8	1.25	16.1	—		—
	GLW50R	●	18.5	M8	1.25	14.6	—		—
GLW50L	●	18.5	M8	1.25	14.6	—	—		
※: 左ねじを示す									
	型番	在庫	寸法 (mm)						
	GLW41R	●	18.5	M8	1.25	16.1	—		—
	GLW41L	●	18.5	M8	1.25	16.1	—		—
	GLW42R	●	18.5	M8	1.25	16.3	—		—
	GLW42L	●	18.5	M8	1.25	16.3	—		—
	GLW51R	●	18.5	M8	1.25	14.6	—		—
	GLW51L	●	18.5	M8	1.25	14.6	—		—
	GLW52R	●	18.5	M8	1.25	14.8	—		—
GLW52L	●	18.5	M8	1.25	14.8	—	—		
※: 左ねじを示す									
	型番	在庫	寸法 (mm)						
	GLWF41R	●	18.5	M8	1.25	13.8	—		—
	GLWF41L	●	18.5	M8	1.25	13.8	—		—
	GLWF80R	●	13	M8	1.25	12.8	—		—
GLWF80L	●	13	M8	1.25	12.8	—	—		
※: 左ねじを示す									
	型番	在庫	寸法 (mm)						
	GTW40R	●	18.5	M8	1.25	15.7	—		—
	GTW40L	●	18.5	M8	1.25	15.7	—		—
	GTW50R	●	18.5	M8	1.25	14.2	—		—
GTW50L	●	18.5	M8	1.25	14.2	—	—		
※: 左ねじを示す									
	型番	在庫	寸法 (mm)						
	GTW41R	●	18.5	M8	1.25	15.9	—		—
	GTW41L	●	18.5	M8	1.25	15.9	—		—
	GTW42R	●	18.5	M8	1.25	16.2	—		—
	GTW42L	●	18.5	M8	1.25	16.2	—		—
	GTW51R	●	18.5	M8	1.25	14.4	—		—
GTW51L	●	18.5	M8	1.25	14.4	—	—		
GTW52R	●	18.5	M8	1.25	14.6	—	—		
GTW52L	●	18.5	M8	1.25	14.6	—	—		
※: 左ねじを示す									
	型番	在庫	寸法 (mm)						
	GTWF41R	●	18.5	M8	1.25	13.7	—		—
	GTWF41L	●	18.5	M8	1.25	13.7	—		—
	GLWF80R	●	13	M8	1.25	12.6	—		—
GLWF80L	●	13	M8	1.25	12.6	—	—		
※: 左ねじを示す									
	型番	在庫	寸法 (mm)						
	CHWR	●	14.5	5.2	18.9	—	—		—
※: 左ねじを示す									
	型番	在庫	寸法 (mm)						
	CEWR	●	10	M8	1.25	19	—		—
※: 左ねじを示す									

部品他

N

部品

資材  
テニアルガイダンス

# 押え金

部品他

N

部品

テニアルガイヌ  
資料

## ■ 押え金

	型番	在庫	寸法 (mm)						
	CCH4R	●	7.5	14	4.8	4.2	6		—
CCH5R	●	10	20	6.3	5.2	8	—		
	型番	在庫	寸法 (mm)						
	PTW40R	●	17	M8	1.25	12.5		—	
PTW40L	●	17	M8	1.25	12.5	—			
※: 左ねじを示す									
	型番	在庫	寸法 (mm)						
	PTW41R	●	17	M8	1.25	12.7		—	
PTW41L	●	17	M8	1.25	12.7	—			
※: 左ねじを示す									
	型番	在庫	寸法 (mm)						
	FMW	●	10.6	14	M7	1	8		13
	型番	在庫	寸法 (mm)						
	RMW	●	11.1	7	8	9		M6	—
	型番	在庫	寸法 (mm)						
	GRHNW	●	9	M6	1	6.5		9.8	—
	型番	在庫	寸法 (mm)						
	CCH3.5	●	7.5	13	3.8	5.5		6.7	—
CCH4.5	●	7.9	14.1	4.8	6.5	7.85	—		
	型番	在庫	寸法 (mm)						
	HTW40R	●	12	9.32	M6	1		12.5	—
	HTW40L	●	12	9.32	M6	1		12.5	—
	HTW50R	●	14	9.76	M6	1		14.8	—
HTW50L	●	14	9.76	M6	1	14.8	—		
※: 左ねじを示す									
	型番	在庫	寸法 (mm)						
	HTW41R	●	12	9.5	M6	1		12.5	—
	HTW41L	●	12	9.5	M6	1		12.5	—
	HTW51R	●	14	10	M6	1		14.8	—
HTW51L	●	14	100	M6	1	14.8	—		
※: 左ねじを示す									

## ■ 押え金

	型番	在庫	寸法 (mm)						
	DSLX8	●	15	29.5	8.5	11	12		—
	型番	在庫	寸法 (mm)						
	FAWR	●	10	6	M7	1		11	—
	型番	在庫	寸法 (mm)						
	HFW	●	11.8	M6	1	8		—	
	型番	在庫	寸法 (mm)						
	AW52R	●	15	10.5	M6	1		—	
	型番	在庫	寸法 (mm)						
	NW41RR	●	12.5	10.1	M6	1		4	—
	NW41RL	●	12.5	10.1	M6	1		4	—
	NW41FR	●	12.5	10.1	M6	1		7	—
NW41FL	●	12.5	10.1	M6	1	7	—		
※: 左ねじを示す									
	型番	在庫	寸法 (mm)						
	NW42RR	●	12.5	10.4	M6	1		5	—
	NW42RL	●	12.5	10.4	M6	1		5	—
	NW42FR	●	12.5	10.4	M6	1		0	—
NW42FL	●	12.5	10.4	M6	1	0	—		
※: 左ねじを示す									
	型番	在庫	寸法 (mm)						
	NW51R	●	16	10.8	M6	1		4	—
	NW51L	●	16	10.8	M6	1		4	—
	NW52R	●	16	10.9	M6	1		0	—
NW52L	●	16	10.9	M6	1	0	—		
※: 左ねじを示す									
	型番	在庫	寸法 (mm)						
	BNRW-08	●	7	37.6	M6	1		7	—
	BNRW-12	●	10	41.6	M8	1		9	—
	BNRW-16	●	13	48.6	M8	1		12	—
BNRW-20	●	16	52.4	M8	1	12	—		



# ブレーカーピース/敷板

## ■ ブレーカーピース

型番	在庫	寸法 (mm)						N-m
		L	H	T	—	—	—	
<b>CBD4R</b>	●	10	15	3.8	—	—	—	—
<b>CBD4L</b>	●	10	15	3.8	—	—	—	—
<b>CBD5R</b>	●	12	20	4.3	—	—	—	—
<b>CBD5L</b>	●	12	20	4.3	—	—	—	—

型番	在庫	寸法 (mm)						N-m
		L	H	T	—	—	—	
<b>CBS13</b>	●	9.3	8.5	1.6	—	—	—	—
<b>CBS14</b>	●	12.5	11.7	2.4	—	—	—	—

型番	在庫	寸法 (mm)						N-m
		L	H	T	—	—	—	
<b>CBT12</b>	●	9.3	8.16	1.6	—	—	—	—

型番	在庫	寸法 (mm)						N-m
		L	H	T	—	—	—	
<b>CBC0903</b>	●	10	8.5	1.6	—	—	—	—

型番	在庫	寸法 (mm)						N-m
		L	H	T	—	—	—	
<b>CBC4</b>	●	12.6	10.7	2.6	—	—	—	—

型番	在庫	寸法 (mm)						N-m
		L	H	T	—	—	—	
<b>CBD1103</b>	●	15.9	8	1.6	—	—	—	—

## ■ 敷板

型番	在庫	寸法 (mm)						N-m
		A	T	d	—	—	—	
<b>LST317</b>	●	9.5	2.7	5.2	—	—	—	—
<b>LST42</b>	●	12.65	3.18	6.9	—	—	—	—

型番	在庫	寸法 (mm)						N-m
		A	T	d	—	—	—	
<b>LSS32</b>	●	9.48	3.18	5	—	—	—	—
<b>LSS42</b>	●	12.65	3.18	6.9	—	—	—	—
<b>LSS53</b>	●	15.85	4.76	7.9	—	—	—	—
<b>LSS63</b>	●	19	4.76	10	—	—	—	—
<b>LSS84</b>	●	25.35	6.35	13.2	—	—	—	—

型番	在庫	寸法 (mm)						N-m
		A	T	d	—	—	—	
<b>LSS42B</b>	●	12.65	3.18	6.9	—	—	—	—

型番	在庫	寸法 (mm)						N-m
		A	T	d	—	—	—	
<b>LSC317</b>	●	9.5	2.7	5.2	—	—	—	—
<b>LSC32</b>	●	9.48	3.18	5	—	—	—	—
<b>LSC42</b>	●	12.65	3.18	6.9	—	—	—	—
<b>LSC53</b>	●	15.85	4.76	7.9	—	—	—	—
<b>LSC63</b>	●	19	4.76	10	—	—	—	—

## ■ 敷板

型番	在庫	寸法 (mm)						N-m
		A	T	d	—	—	—	
<b>LSD317</b>	●	9.5	2.7	5.2	—	—	—	—
<b>LSD42</b>	●	12.65	3.18	6.9	—	—	—	—

型番	在庫	寸法 (mm)						N-m
		A	T	d	—	—	—	
<b>LST317CA</b>	●	9.33	2.7	5	—	—	—	—
<b>LST53</b>	●	15.85	4.76	7.9	—	—	—	—

型番	在庫	寸法 (mm)						N-m
		A	T	d	—	—	—	
<b>LSR817</b>	●	8.4	2.7	5.2	—	—	—	—
<b>LSR10</b>	●	8.4	3.18	4.7	—	—	—	—
<b>LSR12</b>	●	10	3.18	4.7	—	—	—	—
<b>LSR16</b>	●	13.5	4.76	6.3	—	—	—	—
<b>LSR20</b>	●	17.2	4.76	7.9	—	—	—	—
<b>LSR25</b>	●	22	6.35	9.5	—	—	—	—
<b>LSR32</b>	●	28	6.35	12.7	—	—	—	—

型番	在庫	寸法 (mm)						N-m
		A	T	d	—	θ°	—	
<b>LSC42B</b>	●	12.65	3.18	6.9	—	—	8	—

型番	在庫	寸法 (mm)						N-m
		A	T	d	D	—	θ°	
<b>LSW42B</b>	●	12.7	3.18	6.9	15	—	15	—

型番	在庫	寸法 (mm)						N-m
		A	T	d	—	—	—	
<b>STN1103</b>	●	6.3	3.18	3.4	—	—	—	—

型番	在庫	寸法 (mm)						N-m
		A	T	d	—	—	—	
<b>STND323</b>	●	9.3	3.18	3.4	—	—	—	—

型番	在庫	寸法 (mm)						N-m
		A	T	d	—	—	—	
<b>SSN0903</b>	●	9.5	3.18	3.4	—	—	—	—

型番	在庫	寸法 (mm)						N-m
		A	T	d	—	—	—	
<b>SSND423</b>	●	12.5	3.18	3.4	—	—	—	—
<b>SSND433</b>	●	12.5	4.76	3.4	—	—	—	—

型番	在庫	寸法 (mm)						N-m
		A	T	d <sub>1</sub>	d <sub>2</sub>	—	—	
<b>EST32</b>	●	9.53	3.18	5.5	5.9	—	—	—
<b>EST43</b>	●	12.7	4.76	7.5	7.9	—	—	—

部品他

N

部品

資材  
テニアルガイダンス

# 敷板

部品他

N

部品

資材  
テフロンライニング

## ■ 敷板











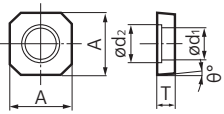

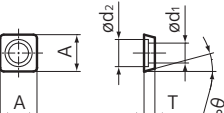

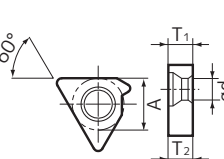

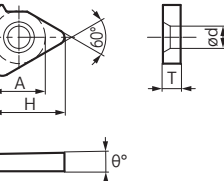
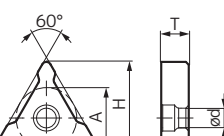
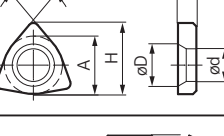

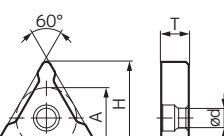
SEC-30 型バイト用 	型番	在庫	寸法 (mm)					N·m
<b>ESS42</b>	●	12.7	3.18	7.5	7.9	—	—	
SEC-30 型バイト用 	型番	在庫	寸法 (mm)					N·m
<b>SCN0903</b>	●	9.5	3.18	3.4	—	—	80	
SEC-30 型バイト用 	型番	在庫	寸法 (mm)					N·m
<b>SDN1103</b>	●	9.5	3.18	3.4	—	—	55	
SEC-40 型バイト用 	型番	在庫	寸法 (mm)					N·m
<b>SCND433</b>	●	12.65	4.76	3.4	—	—	80	
SEC-40 型バイト用 	型番	在庫	寸法 (mm)					N·m
<b>STPD322</b> <b>STPD422</b> <b>STPL42</b>	●	8.4	3.18	3.4	—	—	6	
SEC-40 型バイト用 	型番	在庫	寸法 (mm)					N·m
<b>SSPD422</b> <b>SSPD522</b>	●	11.6	3.18	3.4	—	—	6	
SEC-40 型バイト用 	型番	在庫	寸法 (mm)					N·m
<b>SRND32</b> <b>SRND42</b>	●	—	—	—	—	—	—	
SEC-60 型バイト用 	型番	在庫	寸法 (mm)					N·m
<b>SVW322</b> <b>SDW323</b> <b>SDW423</b> <b>SCW323</b> <b>SCW423</b> <b>SCW635</b>	●	9.5	3.18	4.7	6.5	—	35	
SEC-M 型バイト用 SEC-ボーリングバイト用 	型番	在庫	寸法 (mm)					N·m
<b>STW323</b> <b>STW434</b>	●	9.5	3.18	4.7	6.5	—	—	
SEC-M 型バイト用 	型番	在庫	寸法 (mm)					N·m
<b>SWW433</b>	●	12.65	4.76	6.2	8	—	—	
SEC-M 型バイト用 	型番	在庫	寸法 (mm)					N·m
<b>WNS0603B</b> <b>WNS0803B</b> <b>WNS0804</b> <b>WNS0804B</b>	●	9.525	3.18	3.4	4.5	—	—	

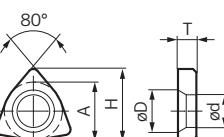
## ■ 敷板



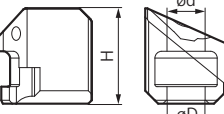

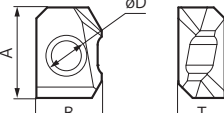
SEC-ボーリングバイト用 	型番	在庫	寸法 (mm)					N·m
<b>SSW423</b> <b>SSW635</b>	●	12.65	3.18	6.2	8	—	—	
SEC-D 型バイト用 	型番	在庫	寸法 (mm)					N·m
<b>CNS1204</b> <b>CNS1606</b> <b>CNS1906</b> <b>CNS2509</b> <b>CNS1204-R24</b>	●	12.57	4.76	4.46	0.80	0.8	1.2	
SEC-D 型バイト用 	型番	在庫	寸法 (mm)					N·m
<b>DNS1504</b> <b>DNS1506</b> <b>DNS1504-R24</b>	●	12.57	6.35	4.4	6	0.80	0.8	
SEC-D 型バイト用 	型番	在庫	寸法 (mm)					N·m
<b>SNS1203B</b> <b>SNS1204</b> <b>SNS1506</b> <b>SNS1906</b> <b>SNS2507</b> <b>SNS2509</b>	●	12.57	3.18	3.44	5	—	—	
SEC-D 型バイト用 	型番	在庫	寸法 (mm)					N·m
<b>TNS1603B</b> <b>TNS1604</b> <b>TNS1604B</b> <b>TNS1604-R24</b>	●	9.525	3.18	3.4	4.5	—	—	
SEC-D 型バイト用 	型番	在庫	寸法 (mm)					N·m
<b>VNS1604</b>	●	9.45	4.76	3.4	4.5	1.2	0.8	
SEC-D 型バイト用 	型番	在庫	寸法 (mm)					N·m
<b>SVP32</b>	●	7.73	3.55	5.5	—	—	—	
Xバーネグインサート用 	型番	在庫	寸法 (mm)					N·m
<b>CNS1203B</b> <b>CNS1204B</b>	●	12.57	3.18	3.44	4.5	1.20	0.8	
Xバーネグインサート用 	型番	在庫	寸法 (mm)					N·m
<b>DNS1104B</b> <b>DNS1506B</b> <b>DNS1504B</b>	●	9.45	4.76	3.4	4.5	1.20	0.8	
SEC-スミデュアルミル DGC 型用 	型番	在庫	寸法 (mm)					N·m
<b>DGCS13R</b>	●	13.7	3.9	6.8	8.8	—	5	

# 敷板/シート/サポート



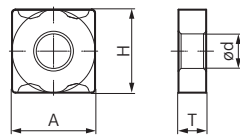

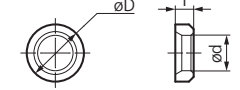
## ■ 敷板

SEC-ウェーブミル WGC/WGX 型用 	型番	在庫	寸法 (mm)							
	<b>WGCS13R</b>	●	A	T	d <sub>1</sub>	d <sub>2</sub>	—	θ°		
			10.7	3	5.5	7.5	—	5	—	
SEC-ウェーブミル WFX 型用 	型番	在庫	寸法 (mm)							
	<b>WFXS4R</b>	●	A	T	d <sub>1</sub>	d <sub>2</sub>	—	θ°		
			10.2	3	5.5	7.5	—	15	—	
LTER (ねじ切り) 用 	型番	在庫	寸法 (mm)							
	<b>LSTE31-0</b>	●	A	T <sub>1</sub>	T <sub>2</sub>	d	—	—		
			9.5	2.7	2.7	5.2	—	—	—	
	<b>LSTE42-0</b>	●	12.65	3.18	3.18	7	—	—	—	
SSTE/SSTI (ねじ切り) 用   	型番	在庫	寸法 (mm)							
	<b>YE3</b>	●	H	A	T	d	θ°	—		
				12.99	9.525	3.2	4.025	0	—	—
	<b>YI3</b>	●	12.99	9.525	3.2	4.025	0	—	—	
	<b>YE3-1P</b>	●	12.99	9.525	3.2	4.025	1	—	—	
	<b>YE3-2P</b>	●	12.99	9.525	3.2	4.025	2	—	—	
	<b>YE3-3P</b>	●	12.99	9.525	3.2	4.025	3	—	—	
	<b>YE3-1N</b>	●	12.99	9.525	3.2	4.025	1	—	—	
	<b>YE3-2N</b>	●	12.99	9.525	3.2	4.025	2	—	—	
	<b>YE3-3N</b>	●	12.99	9.525	3.2	4.025	3	—	—	
	<b>YI3-1P</b>	●	12.99	9.525	3.2	4.025	1	—	—	
	<b>YI3-2P</b>	●	12.99	9.525	3.2	4.025	2	—	—	
	<b>YI3-3P</b>	●	12.99	9.525	3.2	4.025	3	—	—	
	<b>YI3-1N</b>	●	12.99	9.525	3.2	4.025	1	—	—	
<b>YI3-2N</b>	●	12.99	9.525	3.2	4.025	2	—	—		
<b>YI3-3N</b>	●	12.99	9.525	3.2	4.025	3	—	—		
	型番	在庫	寸法 (mm)							
	<b>TRW5505</b>	●	H	A	T	d	—	—		
			14.95	10.54	7.6	3.4	—	—	—	
	型番	在庫	寸法 (mm)							
	<b>LSW317</b>	●	H	A	T	d	D	—		
			10.37	8.53	2.7	4.8	6.2	—	—	
	型番	在庫	寸法 (mm)							
	<b>UF4SR</b>	●	H	L	T	—	—	—		
				14.95	25.45	6	—	—	—	
	<b>UF4SL</b>	●	14.95	25.45	6	—	—	—	—	
	<b>UF5SR</b>	●	17.65	25.15	6	—	—	—		
	<b>UF5SL</b>	●	17.65	25.15	6	—	—	—		
	型番	在庫	寸法 (mm)							
	<b>EHK4R</b>	●	H	d	D	—	—	—		
				14	5.6	5.6	—	—	—	
	<b>EHK5R</b>	●	16	5.6	5.6	—	—	—		
	型番	在庫	寸法 (mm)							
	<b>TSXS13L</b>	●	B	A	T	D	—	—		
			9.6	13.3	6.8	6	—	—	—	



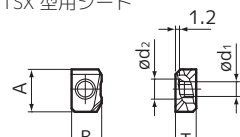

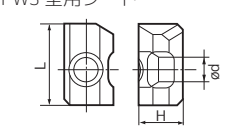
## ■ 敷板

	型番	在庫	寸法 (mm)						
	<b>RMS</b>	●	H	A	T	d	—	—	
			19.05	19.05	6.35	7.93	—	—	—
	型番	在庫	寸法 (mm)						
	<b>LSR917</b>	●	D	d	T	—	—	—	
			9	5.2	2.7	—	—	—	—

## ■ シート

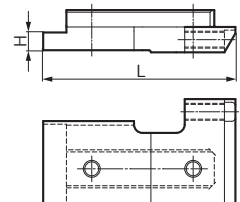
TSX 型用シート 	型番	在庫	寸法 (mm)						
	<b>TSXS13R</b>	●	A	B	T	d <sub>1</sub>	d <sub>2</sub>	—	
			12.7	9	6.2	4.4	6	—	—
PWS 型用シート 	型番	在庫	寸法 (mm)						
	<b>PWSS4R</b>	●	d	L	H	—	—	—	
			4.6	15	8	—	—	—	—

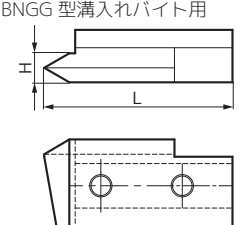
## ■ サポート

BNGG 型溝入れバイト用 	型番	在庫	寸法 (mm)						
	<b>BNGSR200</b>	●	L	H	—	—	—	—	
				44.5	1.2	—	—	—	—
	<b>BNGSR250</b>	●	44.5	1.7	—	—	—	—	
	<b>BNGSR300</b>	●	44.5	2.2	—	—	—	—	
	<b>BNGSR400</b>	●	45	3.2	—	—	—	—	
	<b>BNGSR500</b>	●	45.5	4.2	—	—	—	—	
	<b>BNGSR600</b>	●	46.5	5.2	—	—	—	—	
	<b>BNGSRTT</b>	●	44.5	2	—	—	—	—	
	<b>BNGSL200</b>	●	44.5	1.2	—	—	—	—	
	<b>BNGSL250</b>	●	44.5	1.7	—	—	—	—	
	<b>BNGSL300</b>	●	44.5	2.2	—	—	—	—	
	<b>BNGSL400</b>	●	45.5	3.2	—	—	—	—	
	<b>BNGSL500</b>	●	45.5	4.2	—	—	—	—	
<b>BNGSL600</b>	●	46.5	5.2	—	—	—	—		
<b>BNGSLTT</b>	●	44.5	2	—	—	—	—		
BNGG 型溝入れバイト用 	型番	在庫	寸法 (mm)						
	<b>GTR</b>	●	L	H	—	—	—	—	
				33.9	5.2	—	—	—	—
	<b>GTL</b>	●	33.9	5.2	—	—	—	—	

部品他

N

部品

テフロンガイダンス

# ロケーター/止め輪/ホース/コネクタ/Oリング

## ■ ロケーター

型番	在庫	寸法 (mm)						N·m
		L	H	T	-	-	-	
UF4KR	●	24.6	14	3.8	-	-	-	-
UF4KL	●	24.6	14	3.8	-	-	-	-
UF5KR	●	24.3	16.3	4.5	-	-	-	-
UF5KL	●	24.3	16.3	4.5	-	-	-	-
型番	在庫	寸法 (mm)						N·m
GRKR	●	7	23	11.5	-	-	-	
GRKL	●	7	23	11.5	-	-	-	-
型番	在庫	寸法 (mm)						N·m
LFP4R	●	28.9	21.3	13	-	-	-	
LFP4L	●	28.9	21.3	13	-	-	-	-
LFP5R	●	28.9	21.3	13	-	-	-	-
LFP5L	●	28.9	21.3	13	-	-	-	-
LFE4R	●	28.9	21.3	13	-	-	-	-
型番	在庫	寸法 (mm)						N·m
LNF40R	●	37	19	10	-	-	-	
LNF40L	●	37	19	10	-	-	-	-
型番	在庫	寸法 (mm)						N·m
LAP40R	●	33	20	10	-	-	-	
LAP40L	●	33	20	10	-	-	-	-
型番	在庫	寸法 (mm)						N·m
GL40R	●	35	21	8	-	-	-	
GL40L	●	35	21	8	-	-	-	-
GL50R	●	35	22	9.5	-	-	-	-
GL50L	●	35	22	9.5	-	-	-	-
型番	在庫	寸法 (mm)						N·m
LCP40R	●	38.7	19	11	-	-	-	
LCP40L	●	38.7	19	11	-	-	-	-
型番	在庫	寸法 (mm)						N·m
FMUU	●	39	14.3	15.6	-	-	-	
FMUUE	●	39	14.3	15.6	-	-	-	-
型番	在庫	寸法 (mm)						N·m
GFXK4R	●	29.8	16.9	14	-	-	-	
GFXK4L	●	29.8	16.9	14	-	-	-	-
GFVK5R	●	29.8	16.9	17	-	-	-	-
GFVK5L	●	29.8	16.9	17	-	-	-	-
型番	在庫	寸法 (mm)						N·m
TU05005K1	●	28.5	12.5	9	-	-	-	
TU05506K1	●	28.5	12.5	9	-	-	-	-
TU06507K1	●	28.5	12.5	9	-	-	-	-
TU07508K1	●	28.5	12.5	9	-	-	-	-
TU08509K1	●	28.5	12.5	9	-	-	-	-
TU09510K1	●	28.5	12.5	9	-	-	-	-
TU10513K1	●	28.5	12.5	9	-	-	-	-
TU05005K2	●	28.5	12.5	9	-	-	-	-
TU05506K2	●	28.5	12.5	9	-	-	-	-
TU06507K2	●	28.5	12.5	9	-	-	-	-
TU07508K2	●	28.5	12.5	9	-	-	-	-
TU08510K2	●	28.5	12.5	9	-	-	-	-
TU10512K2	●	28.5	12.5	9	-	-	-	-

## ■ ロケーター

型番	在庫	寸法 (mm)						N·m
		L	H	T	-	-	-	
LCH4R	●	28	20	12.8	-	-	-	-
型番	在庫	寸法 (mm)						N·m
LCE4R	●	30	13	9.7	-	-	-	
型番	在庫	寸法 (mm)						N·m
BNRSR-08	●	6.5	38.5	11	-	-	-	
BNRSR-10	●	8.5	37.1	14	-	-	-	-
BNRSR-12	●	10.4	40.2	16	-	-	-	-
BNRSR-16	●	13	46.5	19	-	-	-	-
BNRSR-18	●	17	49.8	11	-	-	-	-
BNRSR-20	●	17	48.8	21	-	-	-	-

## ■ 止め輪

型番	在庫	寸法 (mm)						N·m
		A	B	T	d	-	-	
ER03	●	7	2.6	0.6	3	-	-	-
ER04	●	9	3.5	0.6	4	-	-	-
ER05	●	11	4.3	0.6	5	-	-	-

## ■ ホース

型番	在庫	寸法 (mm)						N·m
		d	L	-	-	-	-	
J-HOSE-G1/8-G1/8-200	●	8.8	200	-	-	-	-	-
J-HOSE-G1/8-G1/8-300	●	8.8	300	-	-	-	-	-

## ■ コネクタ

型番	在庫	寸法 (mm)							Fig	N·m
		ねじ規格	T1	L	L1	L2	H1	H2		
J-G1/8-R1/4-00	●	R1/4	34	-	-	14	-	1	-	-
J-G1/8-R1/8-00	●	R1/8	29	-	-	14	-	1	-	-
J-G1/8-R3/8-00	●	R3/8	36	-	-	19	-	1	-	-
J-G1/8-R1/4-90	●	R1/4	-	22	25	-	17	2	-	-
J-G1/8-R1/8-90	●	R1/8	-	20	21	-	14	2	-	-
J-G1/8-R3/8-90	●	R3/8	-	23	30	-	19	2	-	-

## ■ Oリング

型番	在庫	寸法 (mm)						N·m
		D	T	-	-	-	-	
SS020	●	2	1	-	-	-	-	-
SS060	●	6	1	-	-	-	-	-
P3	●	2.8	1.9	-	-	-	-	-

部品他

N

部品

テフタルライナス  
資料

# クーラントノズル/C輪/ワッシャー/ピン/ナット/ 引込みピン/アライメント治具/スリーブ/位置決め駒

## ■ クーラントノズル

型番	在庫	寸法 (mm)						N·m
		D	ピッチ	d	L	—	—	
<b>C4-CNZ</b>	●	M8	1.25	7.4	9.9	—	—	—

## ■ C輪

型番	在庫	寸法 (mm)						N·m
		d	H	T	—	—	—	
<b>CR03</b>	●	1.5	3.79	0.4	—	—	—	—

## ■ ワッシャー

型番	在庫	寸法 (mm)						N·m
		d	T	—	—	—	—	
<b>PW3</b>	●	3.3	0.5	—	—	—	—	—

## ■ ピン

型番	在庫	寸法 (mm)							N·m
		d	ピッチ	L	D	D <sub>1</sub>	d <sub>1</sub>	—	
<b>MP317</b>	●	M4	0.7	15.5	6	4	3.7	—	
<b>MP317S</b>	●	M4	0.7	15.5	6	4	3.56	—	
<b>MP320</b>	●	M4	0.7	19.5	6	4	3.7	—	
<b>MP320S</b>	●	M4	0.7	19.5	6	4	3.56	—	
<b>MP416</b>	●	M5	0.8	14	7.5	6	5	—	
<b>MP420</b>	●	M5	0.8	20	7.5	6	5	—	

型番	在庫	寸法 (mm)					N·m
		d	—	L	D	θ°	
<b>SPP308</b>	●	3.2	—	8	4.8	60°	—

型番	在庫	寸法 (mm)				N·m
		—	L	D	—	
<b>SPP3</b>	●	—	14	3.2	—	—

型番	在庫	寸法 (mm)						N·m
		d	H	L	—	—	—	
<b>LSP3</b>	●	5	3.3	5.5	—	—	—	
<b>LSP4</b>	●	6.7	4	7	—	—	—	
<b>LSP5</b>	●	7.7	4.5	8.5	—	—	—	
<b>LSP6</b>	●	9.85	6	11.1	—	—	—	
<b>LSP8</b>	●	13.05	10	12	—	—	—	
<b>LSP10</b>	●	5	3.3	6.5	—	—	—	
<b>LSP16</b>	●	6.6	4.5	9	—	—	—	
<b>LSP20</b>	●	8.2	5.5	9	—	—	—	
<b>LSP25</b>	●	9.8	6.5	11	—	—	—	
<b>LSP32</b>	●	13	10	12	—	—	—	

型番	在庫	寸法 (mm)						N·m
		d	D	L	ℓ	—	—	
<b>LP04</b>	●	0.4	1.1	4.7	3	—	—	
<b>LP06</b>	●	0.4	1.1	6	5	—	—	
<b>LP07</b>	●	0.4	1.1	7.7	3.5	—	—	

型番	在庫	寸法 (mm)								N·m
		d <sub>1</sub>	ピッチ	d <sub>2</sub>	ピッチ	L	D	ℓ <sub>1</sub>	ℓ <sub>2</sub>	
<b>VP20</b>	●	M3.5	0.6	M4	0.7	12	6.5	≥4.5	≥4.5	—
<b>VP25</b>	●	M3.5	0.6	M4	0.7	17	6.5	≥4.5	≥4.5	—
<b>VP32</b>	●	M3.5	0.6	M4	0.7	24	6.5	≥4.5	≥4.5	—

## ■ ピン

型番	在庫	寸法 (mm)						N·m
		d	ピッチ	L	ℓ	D <sub>1</sub>	D <sub>2</sub>	
<b>VP32B</b>	●	M3.5	0.6	8	1.4	5	6.5	—
<b>VP40B</b>	●	M3.5	0.6	11.5	1.4	5	6.5	—

## ■ ナット

型番	在庫	寸法 (mm)						N·m
		d	ピッチ	L	D	B	—	
<b>CPM32N</b>	●	M4	0.7	7.5	7	3	—	
<b>CPM43N</b>	●	M5	0.8	8.5	7	3	—	
<b>CPM43S</b>	●	M5	0.8	6	7	3	—	

型番	在庫	寸法 (mm)						N·m
		L	—	—	—	—	—	
<b>BNBW-4</b>	●	4	—	—	—	—	—	
<b>BNBW-7</b>	●	7	—	—	—	—	—	

型番	在庫	寸法 (mm)						N·m
		d	ピッチ	L	D	B	—	
<b>CPV33N</b>	●	M4	0.5	6	6	2.5	—	
<b>BNBW-2</b>	●	M3	0.5	2	4	—	—	

## ■ 引込みピン

型番	在庫	寸法 (mm)					Fig	N·m
		d	D	L	θ°	—		
<b>SR083</b>	●	5	2.9	20	60	—	—	
<b>SR124</b>	●	6	3.9	24	60	1	—	
<b>SR134B</b>	●	6	3.9	22.5	60	2	—	

## ■ アライメント治具

型番	在庫	寸法 (mm)					N·m
		W	L	T	D	—	
<b>AFBSM60</b>	●	15	34.67	6.05	6	—	—

## ■ スリーブ

型番	在庫	寸法 (mm)				N·m
		L	d	D	—	
<b>HBB616</b>	●	100	6	16	—	—
<b>HBB816</b>	●	100	68	16	—	—

## ■ 位置決め駒

型番	在庫	寸法 (mm)				N·m
		L	B	d	D	
<b>RFS</b>	●	12	2.5	5	10	—

型番	在庫	寸法 (mm)				N·m
		d	ピッチ	D	—	
<b>FMUE</b>	●	M5	0.8	10	—	—

部品他

N

部品

テニールガイメス  
資料

# レンチ

## ■ レンチ

L型レンチ (六角)	型番	在庫	寸法 (mm)						N·m	
			B	L	ℓ	—	—	—		
	LH015	●	1.5	45	14	—	—	—	—	
	LH020	●	2	50	16	—	—	—	—	
	LH020NT	●	2	50	16	—	—	—	—	
	LH025	●	2.5	56	18	—	—	—	—	
	LH025NT	●	2.5	56	6	—	—	—	—	
	LH030	●	3	63	20	—	—	—	—	
	LH035	●	3.5	22	68	—	—	—	—	
	LH040	●	4	70	25	—	—	—	—	
	LH050	●	5	80	28	—	—	—	—	
	LH060	●	6	90	32	—	—	—	—	
LH080	●	8	100	36	—	—	—	—		
L型レンチ (トルクス)	型番	在庫	寸法 (mm)						N·m	
			B	d	L	ℓ	—	—		—
	LT08-06	●	T8	2.3	42.5	6	—	—	—	—
	LT15-10	●	T15	2.8	62	10	—	—	—	—
	LT15	●	T15	3.26	54	17.9	—	—	—	—
	LT20	●	T20	3.9	57.2	19.1	—	—	—	—
	LT25	●	T25	4.4	60.3	20.2	—	—	—	—
	LT27	●	T27	4.96	63.5	21.5	—	—	—	—
レンチ (トルクス)	型番	在庫	寸法 (mm)						N·m	
			B	d	L	ℓ	—	—		—
	LT25NT	●	3.6	4	65	10	—	—	—	—
L型レンチ (トルクスプラス)	型番	在庫	寸法 (mm)						N·m	
			B	L	ℓ	—	—	—		
	LT15IP	●	15IP	55	19	—	—	—	—	—
レンチ (六角)	型番	在庫	寸法 (mm)						N·m	
			B	b <sub>1</sub>	C	—	—	—		
	TH030	●	3	48	28	—	—	—	—	—
	TH040	●	4	48	37	—	—	—	—	—
	TH050	●	5	48	45	—	—	—	—	—
T型レンチ (六角)	型番	在庫	寸法 (mm)						N·m	
			B	b <sub>1</sub>	C	—	—	—		
	TH015	●	1.5	35	30	—	—	—	—	—
	TH020	●	2	35	39	—	—	—	—	—
	TH025	●	2.5	35	39	—	—	—	—	—
	TSW040	●	4	60	20	40	—	—	—	—
ウィングレンチ (六角)	型番	在庫	寸法 (mm)						N·m	
			B	C	b <sub>1</sub>	b <sub>2</sub>	—	—		
	TSW040	●	4	60	20	40	—	—	—	—
ウィングレンチ (トルクスプラス)	型番	在庫	寸法 (mm)						N·m	
			B	d	C	b <sub>1</sub>	b <sub>2</sub>	—		
	TRXW10IP	●	10IP	2.6	40	75	40	—	—	—
T型レンチ (トルクス)	型番	在庫	寸法 (mm)						N·m	
			B	d	C	b <sub>1</sub>	—	—		
	TTX15W	●	T15	4	97	28	—	—	—	—
	TTX20	●	T20	3.9	58	47	—	—	—	—
	TT25	●	T25	4.4	27	48	—	—	—	—
	TT27	●	T27	5	41	48	—	—	—	—

## ■ レンチ

トルクスレンチ	型番	在庫	寸法 (mm)						N·m	
			B	C	b <sub>1</sub>	b <sub>2</sub>	—	—		
	TRX06	●	T6	35.5	15	15	—	—	—	—
	TRX08	●	T8	38.5	19	19	—	—	—	—
	TRX10	●	T10	42.1	22	22	—	—	—	—
	TRX15	●	T15	46	22	27	—	—	—	—
	TRX20	●	T20	49	22	30	—	—	—	—
トルクスレンチ	型番	在庫	寸法 (mm)						N·m	
			B	d	L	ℓ	—	—		
	RT06	●	2-1.8	2	35	8	—	—	—	—
	RT08	●	2-2.1	2.1	35	8	—	—	—	—
トルクスレンチ	型番	在庫	寸法 (mm)						N·m	
			d	C	b <sub>1</sub>	b <sub>2</sub>	B	—		
	RT10	●	3	37	20	20	2.9	—	—	—
トルクスプラスレンチ	型番	在庫	寸法 (mm)						N·m	
			B	C	b <sub>1</sub>	b <sub>2</sub>	—	—		
	TRX06IP	●	6IP	34	15	15	—	—	—	—
トルクスプラスレンチ	型番	在庫	寸法 (mm)						N·m	
			B	C	b <sub>1</sub>	b <sub>2</sub>	—	—		
	TRX08IP	●	8IP	40	25	19	—	—	—	—
T型レンチ (トルクスプラス)	型番	在庫	寸法 (mm)						N·m	
			B	d	C	b <sub>1</sub>	—	—		
	TTR15IP	●	15IP	4	80	25.5	—	—	—	—
ビット (着脱式レンチ先端部)	型番	在庫	寸法 (mm)						N·m	
			B	d	—	—	—	—		
	TRB10IP	●	10IP	4	—	—	—	—	—	—
	TRB15IP	●	15IP	4	—	—	—	—	—	—
	TRB20IP	●	20IP	4.5	—	—	—	—	—	—
	TRB25IP	●	25IP	5	—	—	—	—	—	—
	ハンドグリップ (着脱式柄部)	型番	在庫	寸法 (mm)						N·m
			D	L	備考		—	—		
	HPS1015	●	32	99.4	10IP, 15IP用		—	—	—	—
	HPL2025	●	35.5	110.3	20IP, 25IP用		—	—	—	—
トルクスプラスレンチ (ドライバタイプ)	型番	在庫	寸法 (mm)						N·m	
			B	C	b <sub>1</sub>	—	—	—		
	TRDR08IP	●	8IP	60	104	—	—	—	—	—
	TRDR10IP	●	10IP	80	111	—	—	—	—	—
	TRDR15IP	●	15IP	80	111	—	—	—	—	—
	TRDR20IP	●	20IP	100	118	—	—	—	—	—
	TRDR25IP	●	25IP	100	118	—	—	—	—	—
トルクスレンチ (ドライバタイプ)	型番	在庫	寸法 (mm)						N·m	
			B	d	C	b <sub>1</sub>	—	—		
	TRD07	●	T7	2	45	70	—	—	—	—
	TRD08	●	T8	2.3	55	70	—	—	—	—
	TRD15	●	T15	3.3	70	100	—	—	—	—
	TRD20	●	T20	3.9	100	90	—	—	—	—
	TRD25	●	T25	5.3	80	110	—	—	—	—
六角レンチ (ドライバタイプ)	型番	在庫	寸法 (mm)						N·m	
			B	C	b <sub>1</sub>	—	—	—		
	HD040	●	4	75	111	—	—	—	—	—

部品











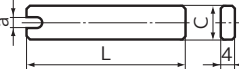

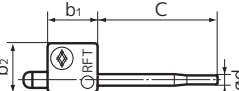

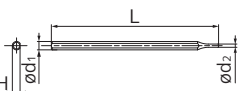
N

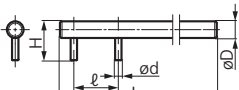
部品

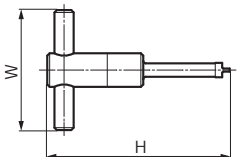
資料  
テニアルガイダンス

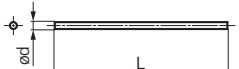
# レンチ/焼付防止剤

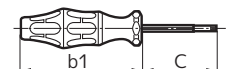
## ■ レンチ

カギレンチ 	型番	在庫	寸法 (mm)						
			L	a	C	—	—	—	
	KY25	●	45	2.5	10	—	—	—	
	KY40	●	60	4	13	—	—	—	
棒レンチ (アジャストねじ操作用 レンチ) 	型番	在庫	寸法 (mm)						
			d	C	b <sub>1</sub>	b <sub>2</sub>	—		—
	RFT	●	1.7	35	15	15	—		—
棒レンチ 	型番	在庫	寸法 (mm)						
			d <sub>1</sub>	d <sub>2</sub>	L	H	—		—
	ANT	●	5	2	100	4.5	—		—
つきくくん用レンチ 	型番	在庫	寸法 (mm)						
			d	D	H	l	L	—	
	SL-1	●	2.3	6	14	16	90	—	
	SL-2	●	2.3	6	14	12	90	—	
	SL-4	●	2.5	6	12	5	90	—	
HFJ用組立専用レンチ 	型番	在庫	寸法 (mm)						
			W	H	—	—	—		—
	HFVT	●	50	76	—	—	—		—
棒レンチ 	型番	在庫	寸法 (mm)						
			d	L	—	—	—		—
	1.8x45	●	1.8	45	—	—	—		—
トルクレンチ 	型番	在庫	寸法 (mm)						
			C	b <sub>1</sub>	—	—	—		—
	TRDR06IP05	●	65	105	—	—	—		—
トルク設定値：0.5 N・m									

## ■ 焼付防止剤

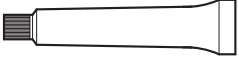
	型番	在庫	内容量 (g)	備考
	SUMI-P	●	5	—
	APM-P	●	15	APM型専用焼付防止剤

# MEMO

