

 **SUMITOMO**

CARBIDE - CBN - DIAMOND

Global Support, Global Solutions.

Igetalloy/SUMIBORON/SUMIDIA



Tooling Solutions for
Automotive Parts

P M K N S H

**SUMITOMO
ELECTRIC
GROUP**

A stellar tool lineup for machining a wide variety of automotive parts

Tooling Solutions for Automotive Parts



INDEX

Cylinder Blocks



P4

Cylinder Heads



P6

Crank Shafts



P8

Cam Shafts

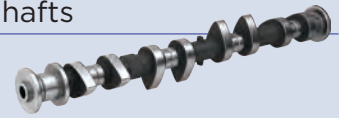

P10

Connecting Rods



P11

Stator Housings



P12

Tansaxle Case



P13

Rotor Shafts/Reduction Gears



P14

Inverter/Converter Cases



P15

Scrolls

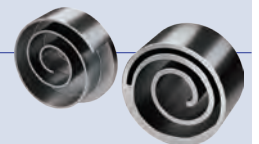

P15

Differential Cases



P16

Motor-on-Calipers

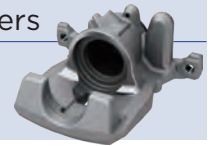

P18

Master Cylinders



P19

Brake Discs/Drums

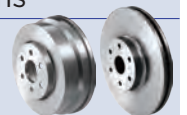

P20

Hubs



P20

Steering Knuckles



P21

Constant Velocity Joints



P22

Axle Beams



P22

Axle Housings



P23

Front Supports



P24

Technical Support

P26

Cylinder Blocks

Aluminum Alloy Cast Iron



Drilling

MULTIDRILL MDA series

Diameter: $\varnothing 1.0$ to 12.0mm
 L/D: $\varnothing 3.0\text{mm}$ or less: 3, 5, 10, 15, 20
 $\varnothing 3.1\text{mm}$ or more: 3, 5, 10



MULTIDRILL MDH series

Diameter: $\varnothing 3.0$ to 14.0mm
 L/D: 3, 5, 8



Reaming

PCD Reamers with Chip Breaking Function Regslash

Diameter: $\varnothing 5.0\text{mm}$ up



3, 4, 5-tooth for Hole Finishing High-efficiency PCD Reamers

Diameter: $\varnothing 7.0\text{mm}$ up



Milling

■ PCD Cutters for High-speed, High-efficiency Milling
ALNEX ANX series



■ For Aluminum Alloy Milling
High-speed Cutters **RF series** Small Diameter Cutters **SRF series**



■ For Journal Width Cutting
Special Side Cutters



■ SEC-Goal Mill
GRHN (M/F) series



■ SEC-Goal Mill
GFX series



■ SEC-Sumi Dual Mill
TGC series



■ High-efficiency Cutters for Cast Iron and Cast Steel Milling
DNX series

- Multi-tooth available



■ SUMIBORON BN Finish Mill/BN Finish Mill EASY
FM series **FMU series**



■ SEC-WaveMill
WEZ series



■ For Boring
Bore Cutters for Roughing



Dedicated Machining

Line Boring Bars For Crank Hole Machining

- Simultaneous machining of all journal sections on a dedicated machine
- Continuous machining from semi-finishing to finishing is possible with the same tool
- Available with oil hole, HSK arbor mounting, etc.



Cylinder Heads

Aluminum Alloy

Cast Iron



Dedicated Machining

VSR Cutters For Hole Finishing of Valve Seat Rings and Stem Guide Holes

- Supports both indexable cutting edge type (insert) and regrindable type (blade) in accordance with requirements
- Carbide or PCD reamers are available

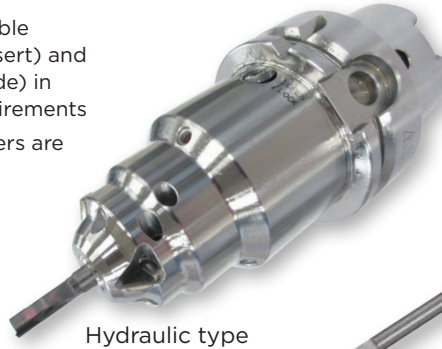

Hydraulic type



Side-locking type
(with runout adjustment mechanism)



Dedicated Machining

PCD Rotating Tools For Cylinder Head Machining A.L.M.T.

- High-precision, stable machining and high surface quality only possible with diamond tools
- Multi-stepped design integrates multiple processes into a single tool



Dedicated Machining

Line Boring Bars For Cam Hole Machining

- Simultaneous machining of all journal sections on a dedicated machine
- Continuous machining from semi-finishing to finishing is possible with the same tool
- Available with oil hole, HSK arbor mounting, etc.



A.L.M.T. indicates A.L.M.T. Corp. products.

Drilling

■ MULTIDRILL
MDA series

Diameter: ϕ 1.0 to 12.0mm
L/D: ϕ 3.0mm or less: 3, 5, 10, 15, 20
 ϕ 3.1mm or more: 3, 5, 10



N

■ For Pre-cast Hole Drilling
DLC Coat High-efficiency Drills

Diameter: ϕ 5.0 to 12.0mm
(large dia. max. ϕ 16.0mm)



N

■ MULTIDRILL
MDH series

Diameter: ϕ 3.0 to 14.0mm
L/D: 3, 5, 8



K

Milling

■ PCD Cutters for High-speed, High-efficiency Milling
ALNEX ANX series

ALNEX



N

■ For Aluminum Alloy Milling
High-speed Cutters **RF series** Small Diameter Cutters **SRF series**



N

■ SEC-WaveMill
WEZ series



N

K

■ High-efficiency Cutters for Cast Iron and Cast Steel Milling
DNX series

• Multi-tooth available



K

■ SEC-Goal Mill
GRHN (M/F) series



K

■ SEC-Goal Mill
GFX series



K

■ SUMIBORON BN Finish Mill/BN Finish Mill EASY
FM series **FMU series**



K

Crank Shafts

Steel

Cast Iron



Dedicated Machining

For Pin/Journal Machining

■ Taper Spline Type

Internal Pin Milling Cutters

External Pin Milling Cutters

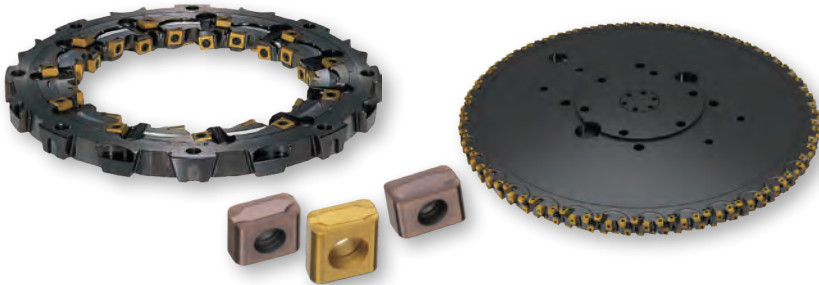

- High rigidity, high precision, easy mounting and removal
- Compatible with formed inserts: Increased number of teeth improves efficiency
- Inserts with chipbreakers: Lower cutting force suppresses thermal damage and improves chip evacuation

Dedicated Machining

For Rear and Front Journal Machining

Turn Broaches



- Traverse cutting, plunging, and broaching are possible
- 30 to 45 units, equivalent to turning holders, can be mounted
- Shortened idling time due to high-speed indexing and long-term automatic operations with optimal unit placements

Milling

■ For Facing

Centring & Facing Cutters



■ SEC-WaveMill

WGX series



■ SEC-WaveMill

WEZ series



Turning

■ Coated Carbide Grades for Steel Turning
AC8100P/AC8000P series

AC8115P
AC8020P
AC8025P
AC8035P

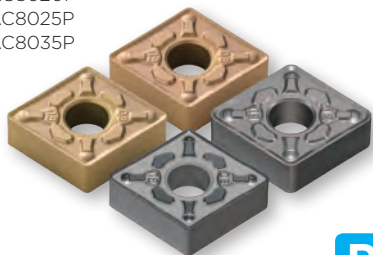

P

■ Coated Carbide Grades For Cast Iron Turning
AC4100K/AC4000K series

AC4010K
AC4015K
AC4125K

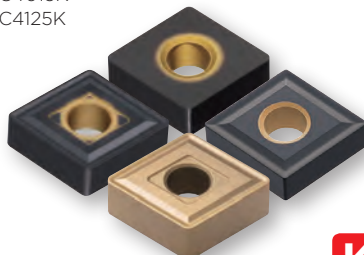

K

■ SEC-Grooving Tools
GND series



■ For Journal Machining
SEC-XD series Holders/Inserts

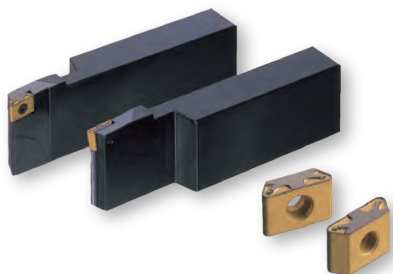

■ For External Turning
SEC-D series Holders



■ For Special-purpose Machining
SEC-Round Insert Holders

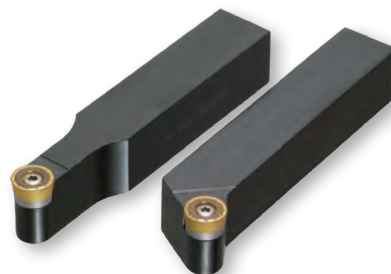

Drilling

■ MULTIDRILL
MDH series

Diameter: $\phi 3.0$ to 14.0mm
L/D: 3, 5, 8



■ Flat MULTIDRILL
MDF series

Diameter: External Coolant Supply:
 $\phi 0.3$ to 20.0mm
Internal Coolant Supply:
 $\phi 3.0$ to 16.0mm
L/D: External Coolant Supply: 2
Internal Coolant Supply: 3, 5



■ Super MULTIDRILL
XHGS series / PHT series for Guide Holes

Diameter: $\phi 2.1$ to 16.0mm
L/D: 10, 12, 15, 20, 25, 30



■ SEC-MULTIDRILL
SMD series

Diameter: $\phi 12.0$ to 30.8mm
L/D: 1.5, 3, 5, 8, 12



■ SumiDrill
WDX series

Diameter: $\phi 13.0$ mm up
L/D: 2 to 5



Cam Shafts

Steel

Cast Iron

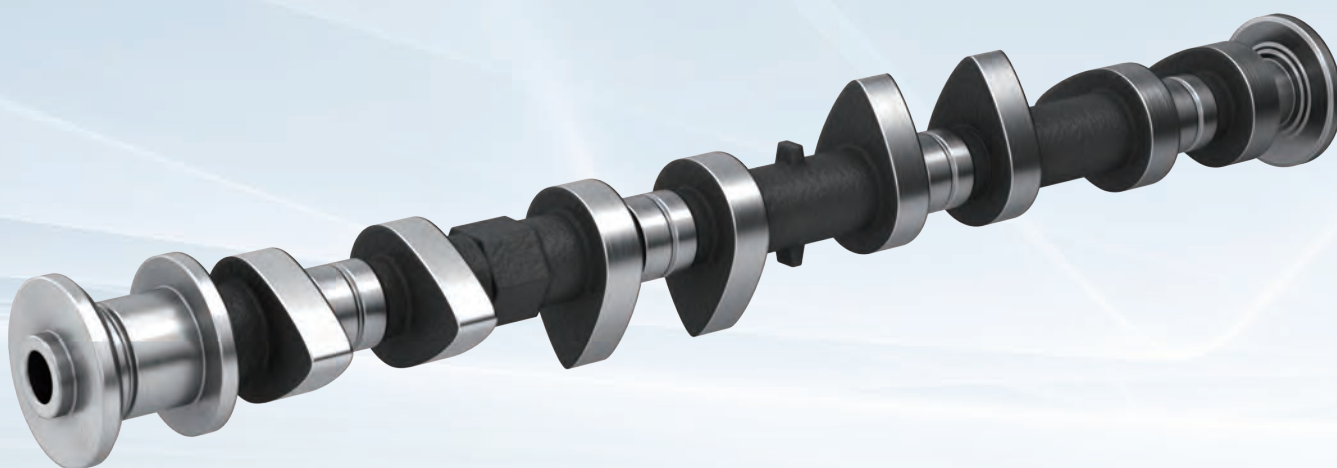

Turning

■ Coated Carbide Grades for Steel Turning
AC8100P/AC8000P series

AC8115P
AC8020P
AC8025P
AC8035P

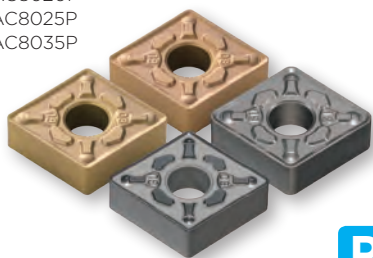

P

■ Coated Carbide Grades For Cast Iron Turning
AC4100K/AC4000K series

AC4010K
AC4015K
AC4125K

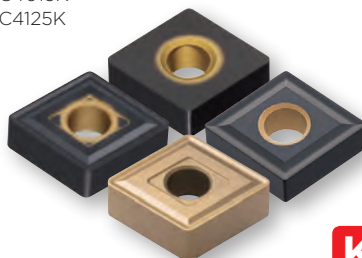

K

■ SEC-Grooving Tools
GND series



Drilling

■ MULTIDRILL
MDH series

Diameter: \varnothing 3.0 to 14.0mm
L/D: 3, 5, 8



■ Flat MULTIDRILL
MDF series

Diameter: External Coolant Supply:
 \varnothing 0.3 to 20.0mm
Internal Coolant Supply:
 \varnothing 3.0 to 16.0mm
L/D: External Coolant Supply: 2
Internal Coolant Supply: 3, 5



■ Super MULTIDRILL
XHGS series / PHT series for Guide Holes

Diameter: \varnothing 2.1 to 16.0mm
L/D: 10, 12, 15, 20, 25, 30



Connecting Rods

Steel



Milling

■ SEC-WaveMill
WGX series



Reaming

■ Indexable type SumiReamer
SR series

Diameter: \varnothing 11.9 to 140.6mm



Drilling

■ SumiDrill
WDX series

Diameter: \varnothing 13.0mm up
L/D: 2 to 5



■ MULTIDRILL NeXEO
MDE series

Diameter: \varnothing 1.0 to 20.0mm
L/D: 2, 3, 4, 5, 8



■ Super MULTIDRILL
XHGS series / PHT series for Guide Holes

Diameter: \varnothing 2.1 to 16.0mm
L/D: 10, 12, 15, 20, 25, 30



Stator Housings

Aluminum Alloy



Dedicated Machining

For Stator Housing/Bearing Mounting Hole Drilling

Special Composite Boring Tools

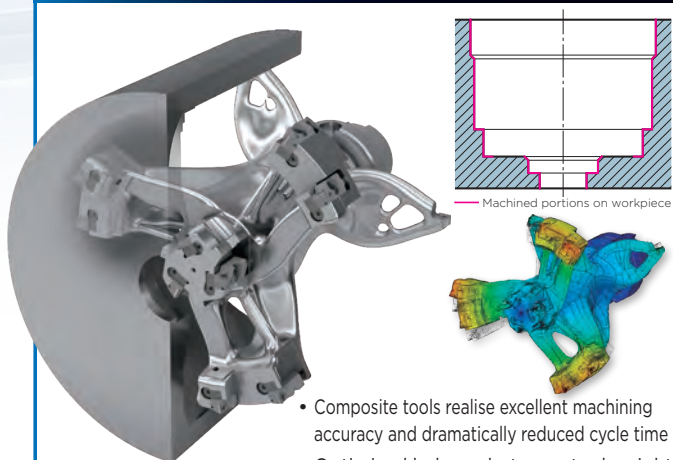

- Composite tools realise excellent machining accuracy and dramatically reduced cycle time
- Optimised balance between tool weight and rigidity based on advanced stress analysis and actual performance data

Dedicated Machining

For Simultaneous Machining of Grooves

Slotting Tools

- Multi-tooth tools dramatically reduce grooving cycle time
- Based on stress analysis, tools are both lightweight and rigid.



Drilling

■ MULTIDRILL
MDA series

Diameter: \varnothing 1.0 to 12.0mm
L/D:
 \varnothing 3.0mm or less:
3, 5, 10, 15, 20
 \varnothing 3.1mm or more:
3, 5, 10



Milling

■ PCD Cutters for High-speed, High-efficiency Milling
ALNEX ANX series

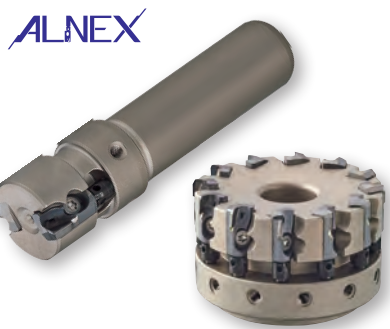

■ SEC-WaveMill
WEZ series



Tansaxle Case

Aluminum Alloy



Dedicated Machining

1-Pass Roughing and Finishing Tools For Bearing Mounting Hole Drilling

Cartridge type

No. of Effective Teeth: 3

Special Formed PCD Inserts with Necking Edge

- The use of three formed inserts enables one-pass finishing even with pre-cast hole materials with large allowance variations
- The introduction of a parallel adjustment mechanism maintains high perpendicular accuracy even when diameter height is adjusted
- The use of an aluminum alloy body also enables use on small machining centres with cutter weight limitations

Brazed type A.L.M.T.

No. of Effective Teeth: 6

PCD Brazed Cutting Edges with Necking Edge

- By brazing the PCD edges directly to the body, the number of effective cutting teeth on the formed cutter can be increased (from 3 to 6), achieving even higher efficiency machining

Drilling

MULTIDRILL MDA series

Diameter: ϕ 1.0 to 12.0mm
 L/D:
 ϕ 3.0mm or less:
 3, 5, 10, 15, 20
 ϕ 3.1mm or more:
 3, 5, 10



For Pre-cast Hole Drilling DLC Coat High-efficiency Drills

Diameter: ϕ 5.0 to 12.0mm
 (large dia. max. ϕ 16.0mm)



Reaming

PCD Reamers with Chip Breaking Function Reglash

Diameter: ϕ 5.0mm up
A.L.M.T.



Rotor Shafts/Reduction Gears

Steel

Ultra-hard Alloy Steel

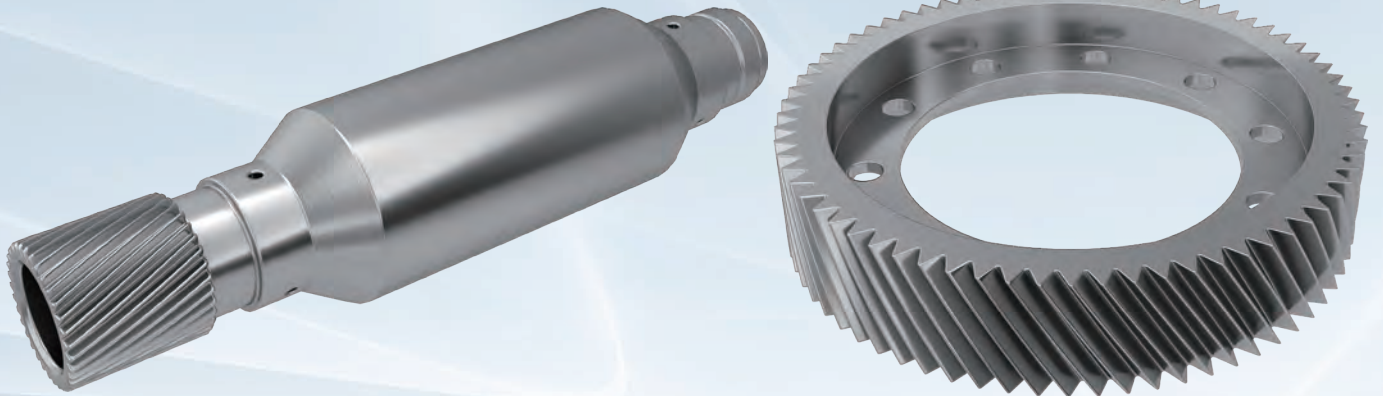

Dedicated Machining

Hard Skiving Tools For High-efficiency Hardened Steel Machining

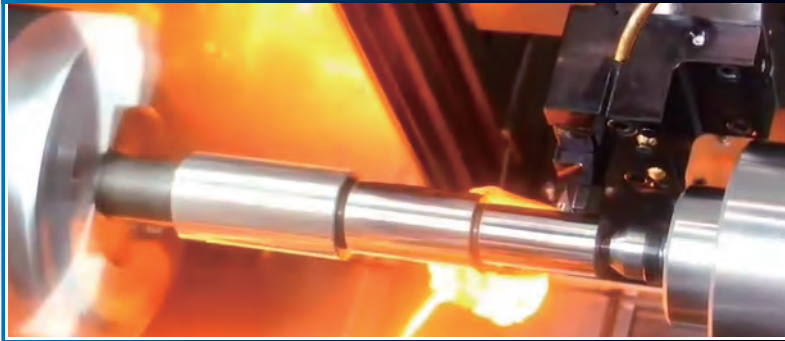

10x machining efficiency compared to conventional machining methods
Surface roughness of **Rz2µm and below** is possible

- Our proprietary machining method achieves both high machining accuracy and high efficiency, significantly shortening cycle time
- Meets the strict machining accuracy requirements of high-speed rotating rotor shafts for EVs

Drilling

MULTIDRILL NeXEO
MDE series

MULTIDRILL
NeXEO
- Next for Everyone -

Diameter: ø1.0 to 20.0mm
L/D: 2, 3, 4, 5, 8



SEC-MULTIDRILL
SMD series

Diameter: ø12.0 to 30.8mm
L/D: 1.5, 3, 5, 8, 12



SumiDrill
WDX series

Diameter: ø13.0mm up
L/D: 2 to 5



Flat MULTIDRILL
MDF series

Diameter: External Coolant Supply: ø0.3 to 20.0mm
Internal Coolant Supply: ø3.0 to 16.0mm
L/D: External Coolant Supply: 2
Internal Coolant Supply: 3, 5



Turning

Coated SUMIBORON
BNC2115/BNC2125

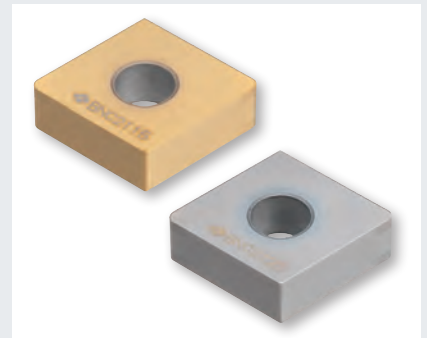

Coated Carbide Grades for Steel Turning
AC8100P/AC8000P series

AC8115P
AC8020P
AC8025P
AC8035P

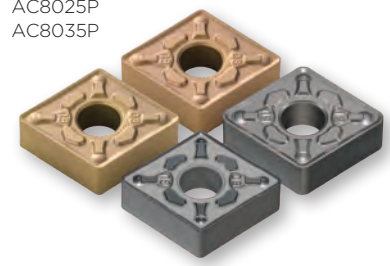

Inverter/ Converter Cases

Aluminum Alloy

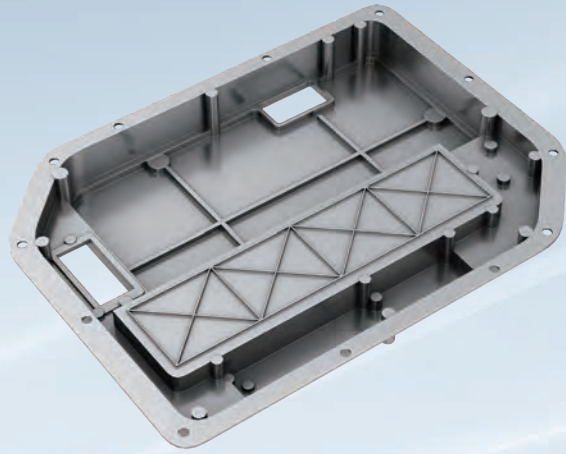

Drilling

MULTIDRILL MDA series

Diameter: $\phi 1.0$ to 12.0mm
L/D: $\phi 3.0\text{mm}$ or less: 3, 5, 10, 15, 20
 $\phi 3.1\text{mm}$ or more: 3, 5, 10



For Pre-cast Hole Drilling DLC Coat High-efficiency Drills

Diameter: $\phi 5.0$ to 12.0mm
(large dia. max. $\phi 16.0\text{mm}$)



Milling

PCD Cutters for High-speed, High-efficiency Milling ALNEX ANX series

ALNEX



AURORA Coat Endmills ASM series



Scrolls

Cast Iron

Aluminum Alloy



Milling

For Scroll Machining Diamond Coated Endmills



For Scroll Machining DLC Coat Endmills



Differential Cases

Cast Iron



Dedicated Machining

Spherical Cutters

Applicable sizes: Consult us (past sizes produced: $\varnothing 35$ to 64mm)

Lay-flat Insert type



- Ideal for small differential case machining

Tangential Insert type



- Tangential orientation increases insert rigidity, ideal for high-feed, high-efficiency machining

Dedicated Machining

Face Cutters

Applicable sizes: Consult us (past sizes produced: $\varnothing 48$ to 100mm)

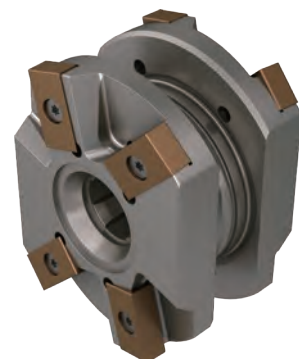

- Special cutters for dedicated machines achieve outstanding mass-production capacity
- High-precision cutter body and ground type insert meet stringent machining accuracy
- Highly economical with indexable insert type

Turning

■ Coated Carbide Grades For Cast Iron Turning
AC4100K/AC4000K series

AC4010K
 AC4015K
 AC4125K

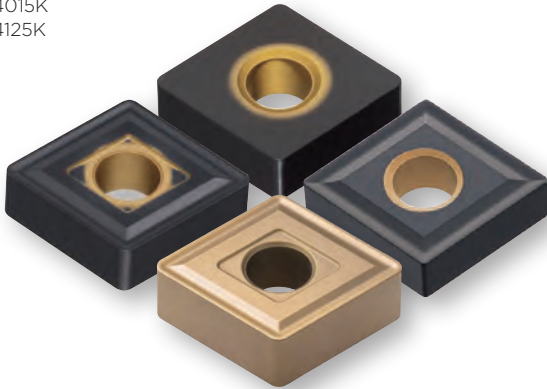

■ Coated SUMIBORON
BNC500



Drilling

■ MULTIDRILL
MDH series

Diameter: \varnothing 3.0 to 14.0mm
 L/D: 3, 5, 8



■ Flat MULTIDRILL
MDF series

Diameter: External Coolant Supply: \varnothing 0.3 to 20.0mm
 Internal Coolant Supply: \varnothing 3.0 to 16.0mm
 L/D: External Coolant Supply: 2
 Internal Coolant Supply: 3, 5



■ SEC-MULTIDRILL
SMD series

Diameter: \varnothing 12.0 to 30.8mm
 L/D: 1.5, 3, 5, 8, 12



Reaming

■ Indexable type SumiReamer
SR series

Diameter: \varnothing 11.9 to 140.6mm



■ SumiReamer
SSR series

Diameter: \varnothing 2.97 to 12.0mm



Motor-on-Calipers

Cast Iron

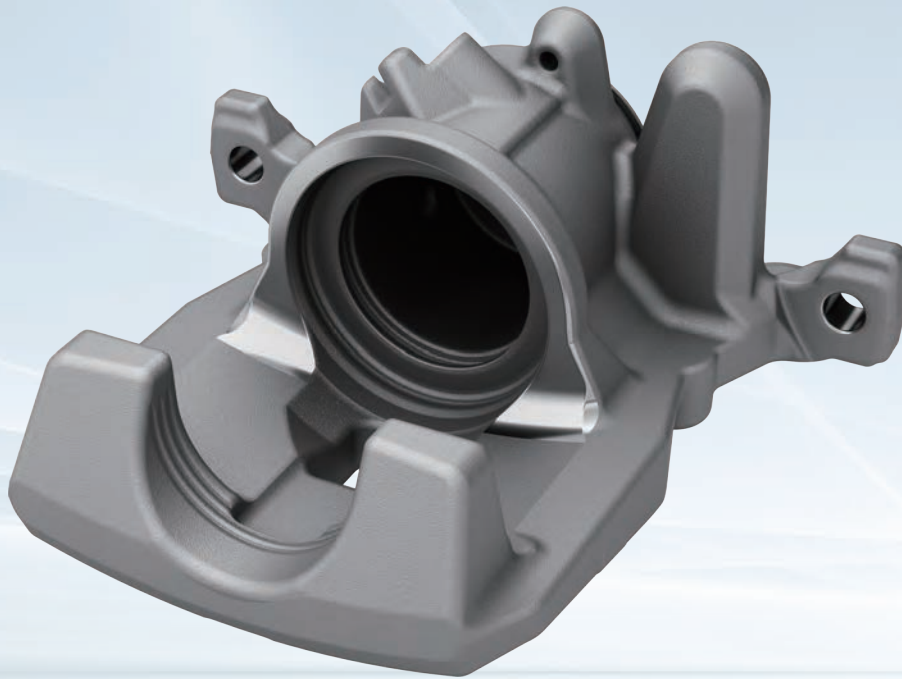

Milling

■ SEC-Sumi Dual Mill
TGC series

Diameter: $\phi 100$ to 200mm
Corner Radius: 0.4 to 3.2

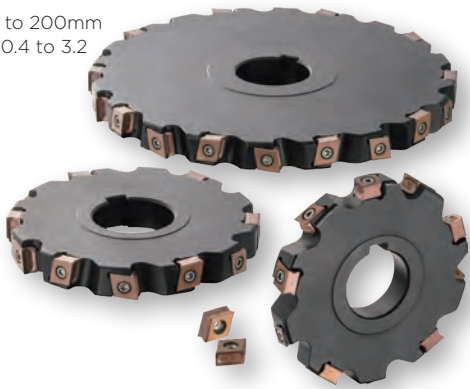

■ For Disc Face Machining
Special Large Corner-R Side Cutters



Boring

■ For Boots Groove Milling
Special Boring Tools

- Achieving high rigidity with a brazed carbide body
- Reduced tool costs due to indexable insert type (compared to brazed tools)
- High-rigidity tangential inserts enable high-feed, high-efficiency machining

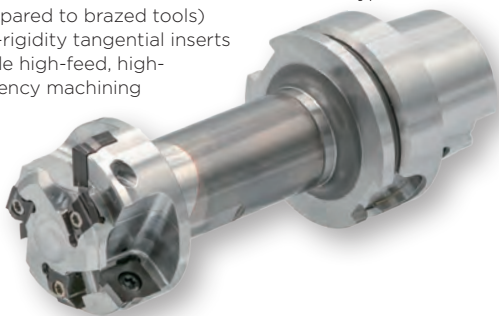

■ For Seal Grooving Milling
Special Boring Tools



Drilling

MULTIDRILL NeXEO

MDE series

MULTIDRILL
NeXEO
- Next for Everyone -

Diameter: \varnothing 1.0 to 20.0mm
L/D: 2, 3, 4, 5, 8



Reaming

Indexable type SumiReamer

SR series

Diameter: \varnothing 11.9 to 140.6mm



Turning

Coated Carbide Grades For Cast Iron Turning

AC4100K/AC4000K series

AC4010K
AC4015K
AC4125K

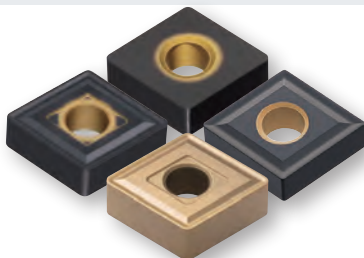

Coated SUMIBORON

BNC500



Master Cylinders

Aluminum Alloy



Drilling

MULTIDRILL

MDA series

Diameter: \varnothing 1.0 to 12.0mm
L/D: \varnothing 3.0mm or less: 3, 5, 10, 15, 20
 \varnothing 3.1mm or more: 3, 5, 10



Milling

PCD Cutters for High-speed, High-efficiency Milling

ALNEX ANX series

ALNEX



Brake Discs/ Drums

Steel

Cast Iron



Brake Drums

Disc Brakes

Turning

■ SEC-Grooving Tools
GND series



■ Coated Carbide Grades For Cast Iron Turning
AC4100K/AC4000K series

AC4010K
AC4015K
AC4125K

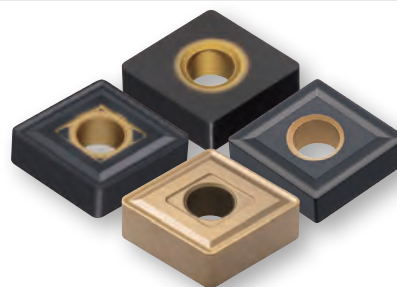

Hubs

Steel



Drilling

■ MULTIDRILL NeXEO
MDE series

MULTIDRILL
NeXEO
- Next for Everyone -

Diameter: ϕ 1.0 to 20.0mm
L/D: 2, 3, 4, 5, 8

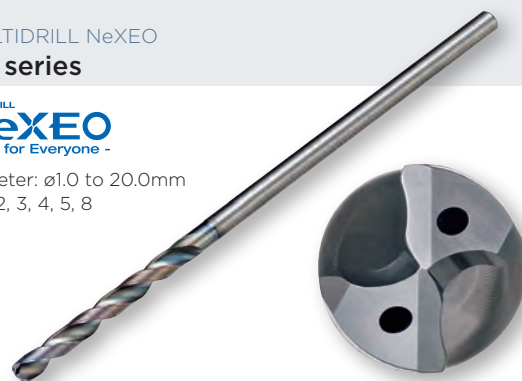

Turning

■ Coated Carbide Grades for Steel Turning
AC8100P/AC8000P series

AC8115P
AC8020P
AC8025P
AC8035P

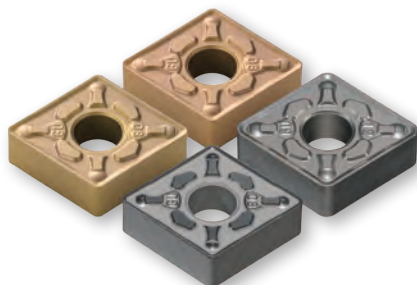

■ Coated SUMIBORON
BNC500

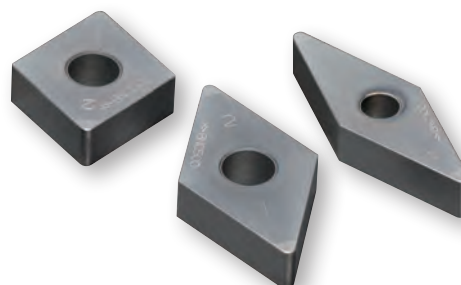

Steering Knuckles

Cast Iron

Aluminum Alloy



Drilling

MULTIDRILL MDH series

Diameter: ϕ 3.0 to 14.0mm
L/D: 3, 5, 8



MULTIDRILL MDA series

Diameter: ϕ 1.0 to 12.0mm
L/D: ϕ 3.0mm or less: 3, 5, 10, 15, 20
 ϕ 3.1mm or more: 3, 5, 10



Milling

SEC-Sumi Dual Mill TGC series

Diameter:
 ϕ 100 to 200mm
Corner Radius:
0.4 to 3.2



Boring

Hub Bearing Hole Finishing Special Boring Tools

- With cutting edge/
overhang adjustment
mechanism

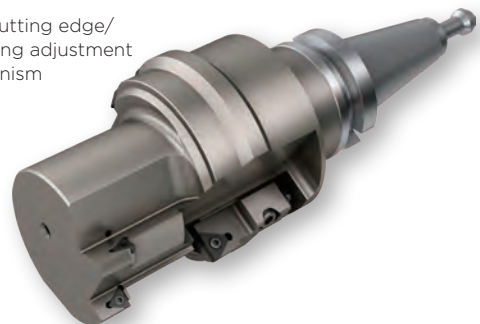

Constant Velocity Joints

Steel



Axle Beams

Steel



Drilling

SEC-MULTIDRILL SMD series

Diameter: \varnothing 12.0 to 30.8mm
L/D: 1.5, 3, 5, 8, 12



SumiDrill WDX series

Diameter: \varnothing 13.0mm up
L/D: 2 to 5

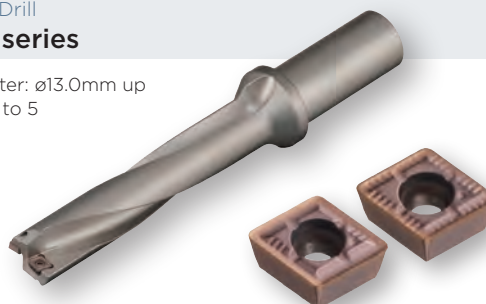

Milling

SEC-Sumi Dual Mill DMSL series / DMSW series



SEC-WaveMill WEZ series

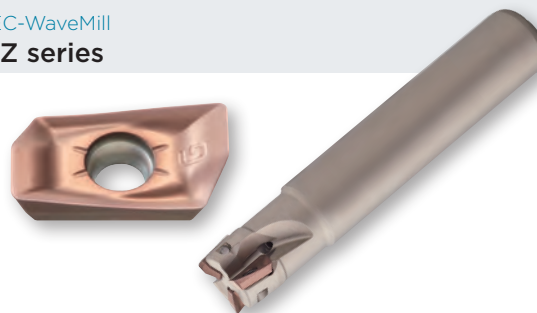

Milling

■ CBN Endmills for CVJ Machining
HDS series



■ SUMIBORON Helical Endmills
Helical Master BNES series



Axle Housings

Steel



Drilling

■ MULTIDRILL NeXEO
MDE series

MULTIDRILL
NeXEO
- Next for Everyone -

Diameter: \varnothing 1.0 to 20.0mm
L/D: 2, 3, 4, 5, 8



Milling

■ SEC-Sumi Dual Mill
TSXR series

L/D: 1.5, 3, 5, 8, 12

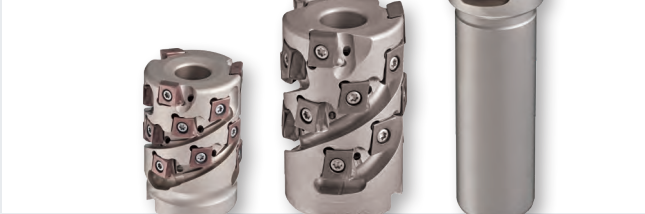

■ SEC-Sumi Dual Mill
DGC series



Front Supports

Cast Iron

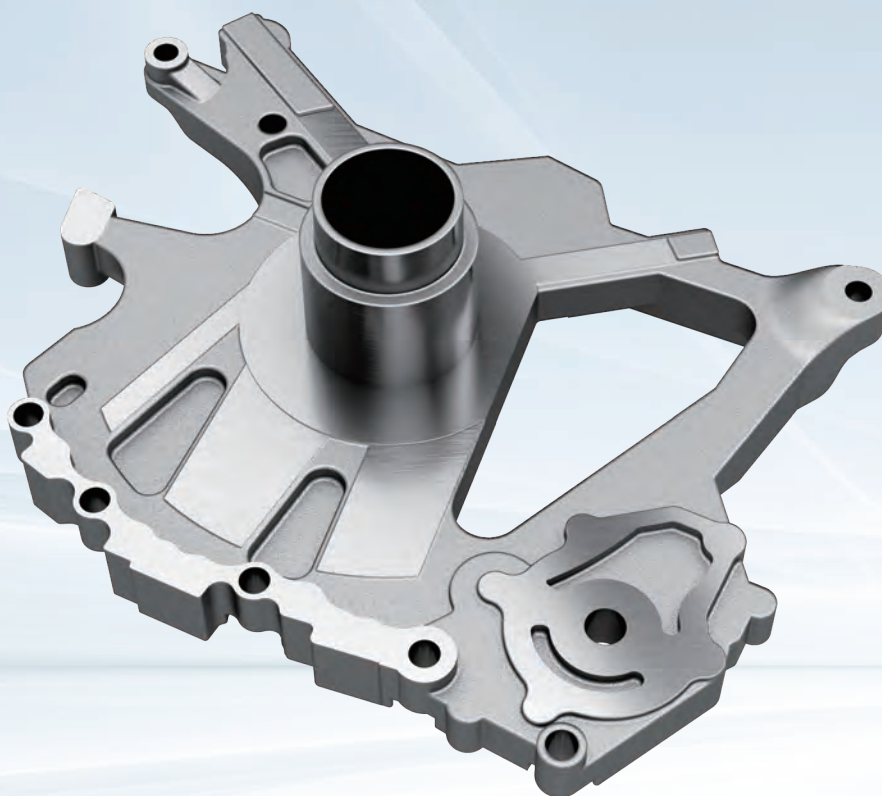

Drilling

■ MULTIDRILL NeXEO
MDE series

MULTIDRILL
NeXEO
- Next for Everyone -

Diameter: \varnothing 1.0 to 20.0mm
L/D: 2, 3, 4, 5, 8



■ SEC-MULTIDRILL
SMD series

Diameter: \varnothing 12.0 to 30.8mm
L/D: 1.5, 3, 5, 8, 12



Milling

■ SEC-WaveMill
WEZ series

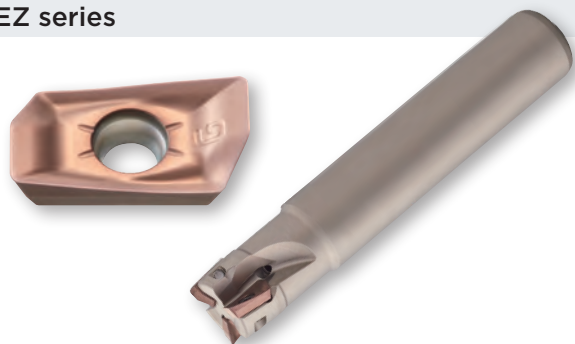

■ SEC-Goal Mill
GFX series



MEMO

A large grid of dotted lines for writing a memo. The grid consists of 20 columns and 30 rows of small, evenly spaced dots, forming a guide for handwriting.

Technical Support

We support customers in solving problems with optimal machining methods through tool proposals and resolution of machining issues.

Tooling Support Plus

We provide a report and proposal containing the information required on machining sequence, tools, cutting conditions, and so on.



1 Consult us
 ● Provide the required information such as product drawings, etc.

2 Tooling proposal
 ● Tool selection/CAM proposal
 ● Time study

3 Support for cutting tests
 ● Use of TEC
 ● Sensing tools

4 Follow-up
 ● Problem investigation
 ● Program analysis

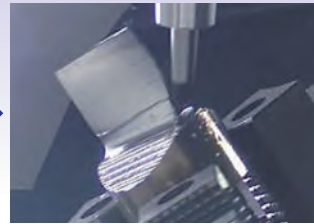
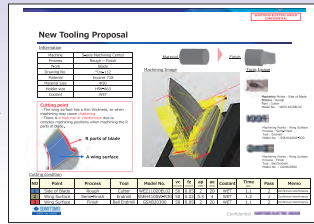
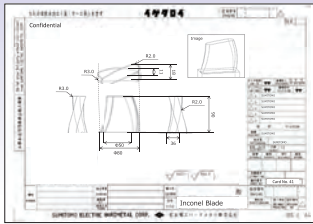

We will provide a report containing all the necessary information on machining.

For actual cutting tests, please contact your local Tool Engineering Center.

- * Proposed reports will be kept strictly confidential, and any information obtained in the course of business will not be disclosed or provided to any third party.
- * Tooling Support Plus is mainly conducted in Itami and Yokohama. Contact our sales personnel for more details.

No.	Point	Process	Tool	Model No.	VC	Fz	DP	DC	Coolant	Time	Pass	Mining
1	Side of Blade	Grinding	Grinder	MTZ11020102	SP	0.05	2	30	WET	1:1	1	Grinding
2	Milling Surface	Soft Machining	Endmill	SD50410014008	SP	0.12	0.7	4	WET	1:1	1	Soft Machining
3	Milling Surface	High Speed	Ball Endmill	SD5050200	SP	0.05	2	20	WET	1:1	1	High Speed

Technical Consultation

We offer support using CAM.



Drastically shortening machining time by eliminating unnecessary tool passes and using a Sumitomo high-feed cutter (example)

Before 29 min 21 sec

Current cutter: $\varnothing 80\text{mm}$
 Spindle speed $n = 915\text{min}^{-1}$, Feed rate per tooth $fz = 0.2\text{mm/t}$
 Feed rate $vf = 1830\text{mm/min}$, Depth of cut $ap = 3\text{mm}$

- Depth of cut increased
- No. of passes reduced
- Machining time shortened
- Machining time reduced by 50%

After 14 min 35 sec

DMSW type: $\varnothing 80\text{mm}$
 Spindle speed $n = 637\text{min}^{-1}$, Feed rate per tooth $fz = 1.5\text{mm/t}$
 Feed rate $vf = 7640\text{mm/min}$, Depth of cut $ap = 1.5\text{mm}$

Proposal Examples Here we introduce a few Tooling Support Plus examples.



Reducing number of tools

FC250 Railway Component

Cutting Tool
 T1 : MDE1000S10E02
 T2 : WFX08020E ø20, 2 teeth
 SOMT080304PZER-G
 (ACK200)

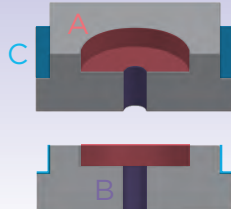

Before	After
No. of Tools: 3	No. of Tools: 2
A Part: Spot Facing ↓ Conventional Tool	B Part: Drilling ↓ T1
B Part: Drilling ↓ Conventional Tool	A Part: Spot Facing ↓ Conventional Tool
C Part: Endmilling ↓ Conventional Tool	C Part: Endmilling ↓ T2

Tool path proposal using CAM

NAK80 Tapered Hole Milling

Cutting Tool
 T3 : SMDH320-1.5D SMDT3200MTL
 T4 : DMSW08035E02
 WNMU0807ZNER-G (ACU2500)

(1) x20 positions (2) x15 positions
 (3) x20 positions

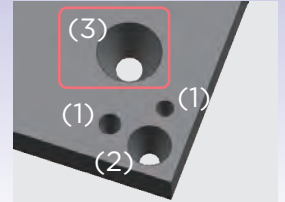

Before	After
Machining Time 96 min	Machining Time 58 min
Optimal tool path proposal	High-feed cutter introduced
T3.Prepared Hole Drilling	T4.Rough Tapered Hole Milling
	T4.Finishing

Reduced Chatter

SKD61 Mold Component

Cutting Tool
 MA18M10L200C Carbide Arbor
 MSX06020M10Z3 ø20, 3 teeth
 WDMT0804ZDTR (ACP300)
 $vc = 150\text{m/min}$ $fz = 0.8\text{mm/t}$
 $ap \times ae = 1.0 \times 7.5\text{mm}$, Wet

Additional Tool
 WDX130D5S20
 WDXT042004-G (ACP300)
 $vc = 180\text{m/min}$
 $f = 0.08\text{mm/rev}$, Wet

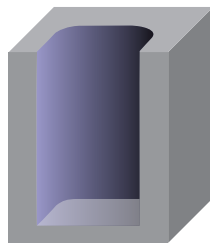

Before	After
[Cause] Chatter in simultaneous engagement	Addition of roughing process

Improved Productivity

FC250 Automotive Component

Current Tool: Conventional Tool ø32, 4 teeth
 Insert: Conventional Insert and Grade
 Cutting Conditions: $vc = 150\text{m/min}$
 $f = 0.1\text{mm/rev}$, Dry

Proposed Tool: WEZ17032E03 ø32, 3 teeth
 Insert: AOMT170504PEER-G
 (ACU2500)
 Cutting Conditions: $vc = 150\text{m/min}$
 $fz = 0.13\text{mm/t}$, Dry

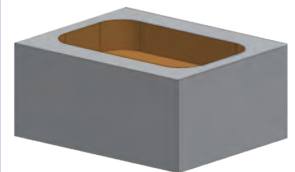

Before	After
With Central Insert Effective No. of Teeth: 1 Machining Time 18 sec	No Central Insert Effective No. of Teeth: 3 Machining Time 12 sec

Contact our local sales office for details.

< SAFETY NOTES >



• Very hot or lengthy chips may be discharged while the machine is in operation. Therefore, machine guards, safety goggles or other protective covers must be used. Fire safety precautions must also be considered.

• Please handle with care as this product has sharp edges.
• Improper cutting conditions or mis-handling of the tool may result in breakages or projectiles. Therefore, please use the tool within its recommended conditions.

• When using non-water soluble cutting oil, precautions against fire must be taken and please ensure that a fire extinguisher is placed near the machine.

 Sumitomo Electric Industries, Ltd.

<https://www.sumitool.com/global>



Hardmetal Division

Global Marketing Department : 1-1-1, Koyakita, Itami, Hyogo 664-0016, Japan

 A.L.M.T. Corp.

<https://www.allied-material.co.jp/en.html>



Sumitomo Fudosan Shiba Building, 1-11-11, Shiba, Minato-ku, Tokyo 105-0014, Japan