

High-Efficiency Milling Cutter for Aluminum Alloy

ALNEX ANX series

Rev.6

**Ultra-High-Efficiency
Machining
Excellent Chip Control**

CVD Single Crystal Diamond
SCV10
Japan Cutting & Wear-resistant
Tool Association
Technical Achievement Award

2019-006 2022-019
JTA ECO PRODUCT JTA ECO PRODUCT
★★★★★ (ANX) ★★★★★ (SCV10)



New New expanded grade DA1090
realizes stable combined milling of
aluminum alloy and cast iron

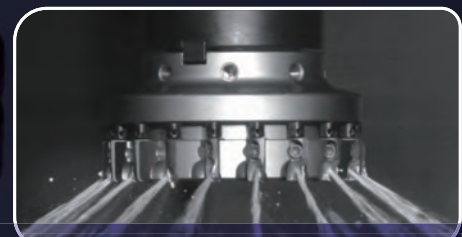



Blade Through Coolant







■ **Features**

- **Drastically Reduced Runout Adjustment Time**
Simple screw-fastening structure enables fine adjustments to be made easily
- **Through-Blade Coolant**
Ensures coolant supply to the cutting edge and breaks chips
- **Lightweight Aluminum Alloy Body (ANXA Type)**
Utilizes aluminum alloy to achieve a total weight of less than 1.3kg for a ø125mm cutter with 22 teeth
- **High-strength CVD Single Crystal Diamond SCV10 Wiper Blade WS type**

■ **Product Range**

| Type | Cat. No. | Body Material | Max. Diameter (mm) | | | | | | | | | | |
|---------|---|----------------|--------------------|-----|-----|-----|-------|--------|---------|---------|----------|----------|----------|
| | | | ø25 | ø30 | ø32 | ø40 | ø50 | ø63 | ø80 | ø100 | ø125 | ø160 | |
| Shell | ANXA 16000R  | Aluminum Alloy | | | | | | | | 6 10 14 | 8 12 18 | 10 14 22 | 12 20 28 |
| | ANXA 16000RS | Aluminum Alloy | | | | | | | | 6 10 14 | 8 12 18 | 10 14 22 | 12 20 28 |
| | ANXS 16000R  | Steel | | | | | | | 6 8 12 | 6 10 14 | 8 12 18 | 10 14 22 | |
| | ANXS 16000RS | Steel | | | | 4 6 | 4 6 9 | 6 8 12 | 6 10 14 | 8 12 18 | 10 14 22 | | |
| Shank | ANXS 16000E | Steel | 2 | 3 4 | 3 4 | 4 6 | 4 6 9 | | | | | | |
| Modular | ANXS 16000M | Steel | 2 | 3 4 | 3 4 | 4 6 | | | | | | | |

Number in    shows the number of teeth  Inch Bore

■ **Blade Selection Guide**

| Work Material | N | | | | | | | | |
|--------------------|-------------------------|-----------------|-----------|---------------|--------------------------------|-----------------------|-----------------------|-----------|------------------------------|
| Applications | Finishing/Light Cutting | General-purpose | Roughing | | Combined Milling ^{*1} | Corner Radius Milling | Corner Radius Milling | Finishing | Burr-free / Mirror Finishing |
| Features | Low Cutting Force | Standard | Long Edge | High Strength | High Strength | Corner Radius 0.4 | Corner Radius 0.8 | Wiper | Wiper |
| Cutting Edge Shape | L | G | GX | H | GB | - | - | W | WS |
| Edge Length (*2) | 6.0mm | 6.0mm | 9.0mm | 6.0mm | 6.0mm | 6.0mm | 6.0mm | 2.0mm | 1.0mm |

*1 Machining of components combining aluminum alloy and cast iron. W type and WS type cannot be used together.

■ **Blade Selection Reference**

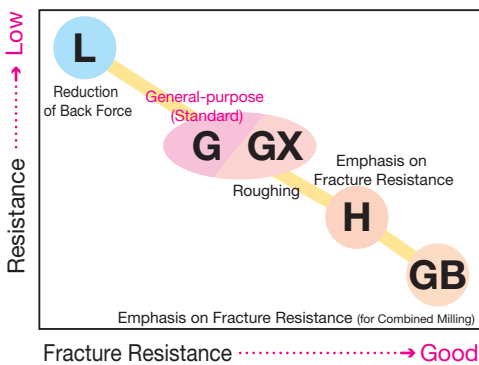

● **Regrinding possible up to 1.0mm. Reduced running costs**

Assuming 0.2mm of regrinding each time, an edge can be used up to 6 times. (Peripheral edge and WS type cannot be regrind.)

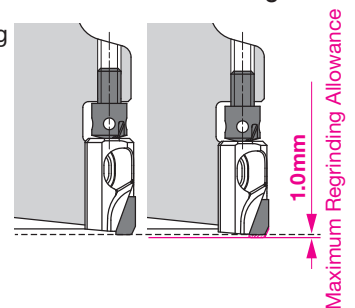
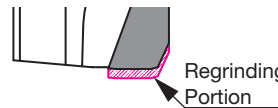

■ **High-speed/High-efficiency Cutting**

Realizes ultra-high-efficiency machining with $vf = 30,000\text{mm}/\text{min}$



Cutter diameter ø100mm comparison

| | Spindle Speed min^{-1} | Number of Teeth | Feed Rate vf (mm/min) |
|------------------------|---------------------------------|-----------------|-------------------------|
| ALNEX ANX series | 18,000 | 18 | 32,400 |
| Competitor's Product A | 9,500 | 12 | 11,400 |

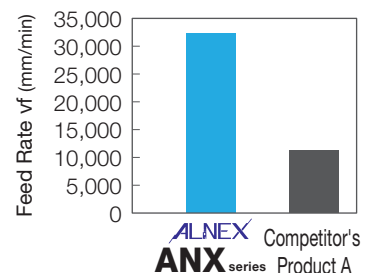

■ Drastically Reduced Runout Adjustment Time

- Simple screw-fastening structure
- Enables fine adjustments to be made easily
- High-rigidity body (reduces deformation due to tightening)

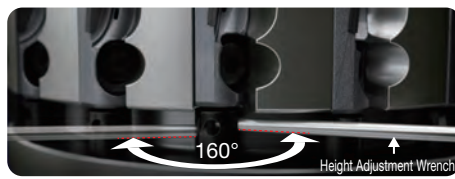
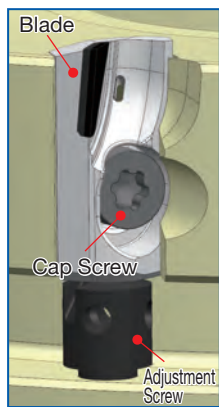

Adjustment is easy thanks to the large movable range of the height adjustment wrench.



We recommend keeping cutting edge height variation during runout adjustment to within 5µm.

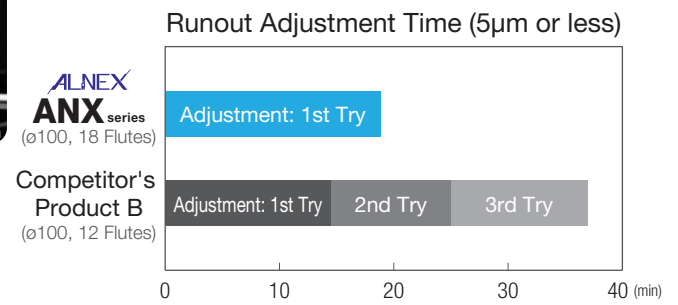

Completed on 1st Try, Adjustment Time Reduced

* Because the cutting edge chips off easily, care is required when mounting on the cutter body. Use a non-contact tool presetter.

■ Blade Mounting/Runout Adjustment

- (1) Slide the blade into the cutter teeth groove.
- (2) Lightly tighten the cap screw while pressing the blade against the restraining face. (1N·m)
- (3) Adjust the blade to the required height by using the dedicated wrench to turn the height adjustment screw.
- (4) Perform final tightening of the cap screw. (2N·m)

■ Chip Control

Through-Blade Coolant Chip Breaking

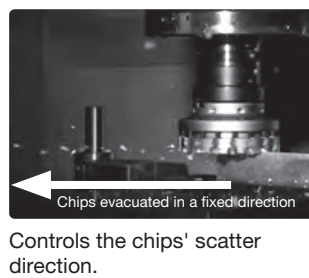
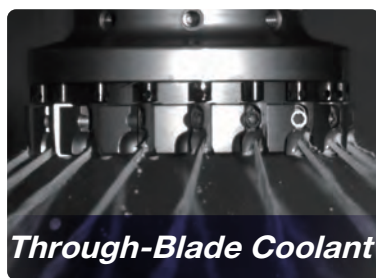

The chip pocket catches the chips and suppresses damage to the body.

Work Material: ADC12, Cutting Conditions: $v_c = 2,500\text{m/min}$ $f_z = 0.05\text{mm/t}$ $a_p = 0.5\text{mm}$ Wet

■ Burr Control

Reduces burrs by using a double-chamfered cutting edge (L/G/GX/H/GB Types)

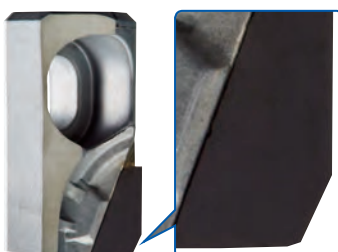

Drastically reduces burrs by preventing plastic deformation that causes burrs.

Work Material: A6061 Sheet Metal
Cutting Conditions: $v_c = 3,142\text{m/min}$
 $f_z = 0.1\text{mm/t}$
 $a_p = 0.5\text{mm}$ Dry

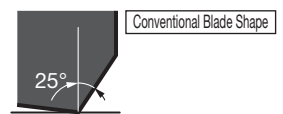
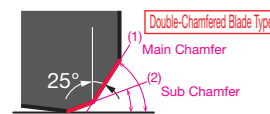

ALNEX ANX series

Conventional Tool

CVD Single Crystal Diamond SCV10 Wiper Blade WS Type



- Wiper blade adopts high-strength single-crystal diamond using Sumitomo Electric Hardmetal's vapor phase synthesis technology
- Sharp cutting edge achieves burr-free mirror finish in aluminum alloy machining
- Superior wear resistance maintains cutting edge sharpness for a long time, reducing total tool costs



Conventional single-crystal diamond



◆ Superb mirror surface and burr control through sharp cutting edge

Realizes a mirror finish in milling of aluminum alloys, copper alloys, and other non-ferrous metals, with long-term burr control

■ Mirror Finish (Wiper Blade WS Type)

Sharp cutting edge achieves mirror finish with cutting alone

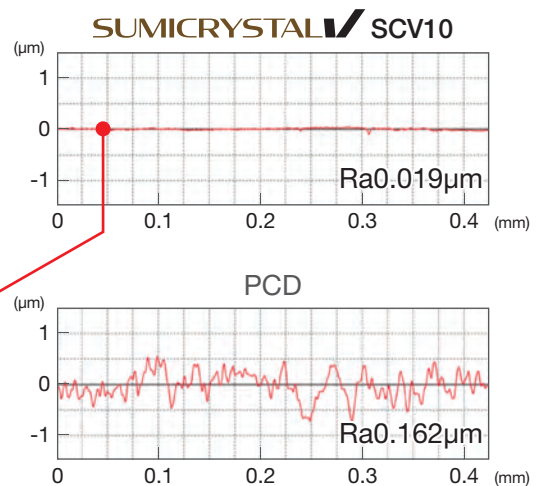
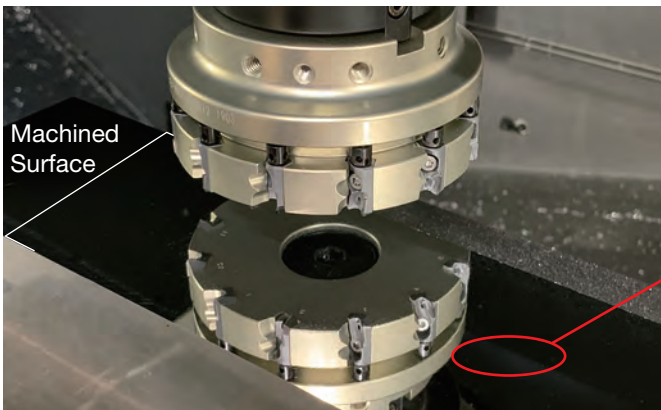

■ Burr-Free (Wiper Blade WS Type)

Sharp cutting edge and excellent wear resistance suppress burrs over a long period

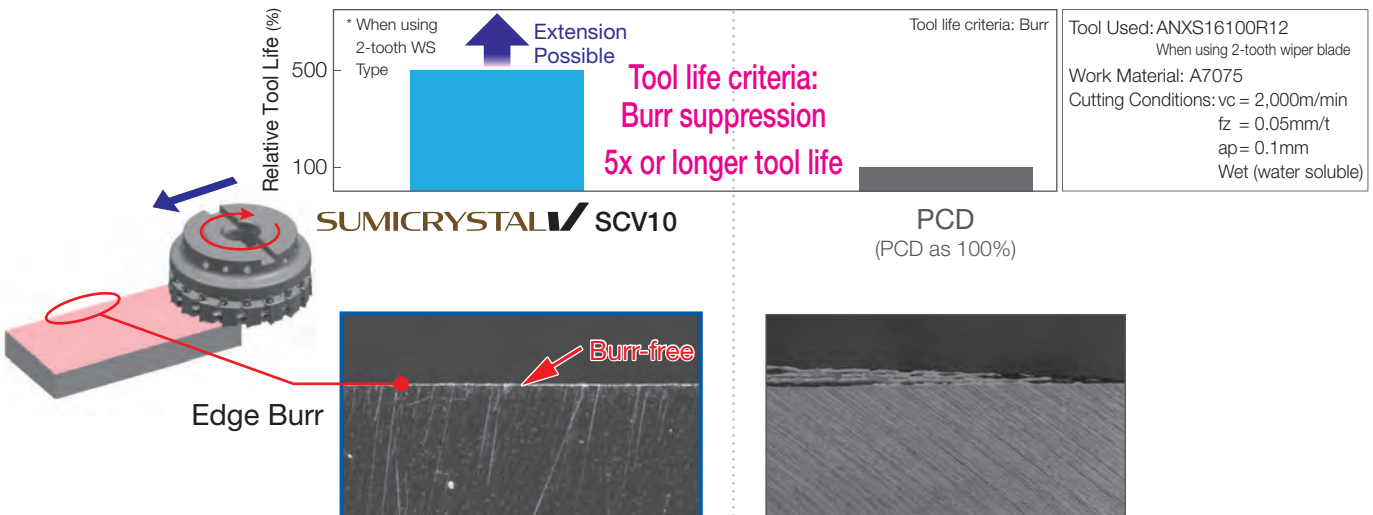

◆ Superior wear resistance maintains cutting edge sharpness for a long time

Wear resistance evaluation in high-silicon aluminum alloy machining

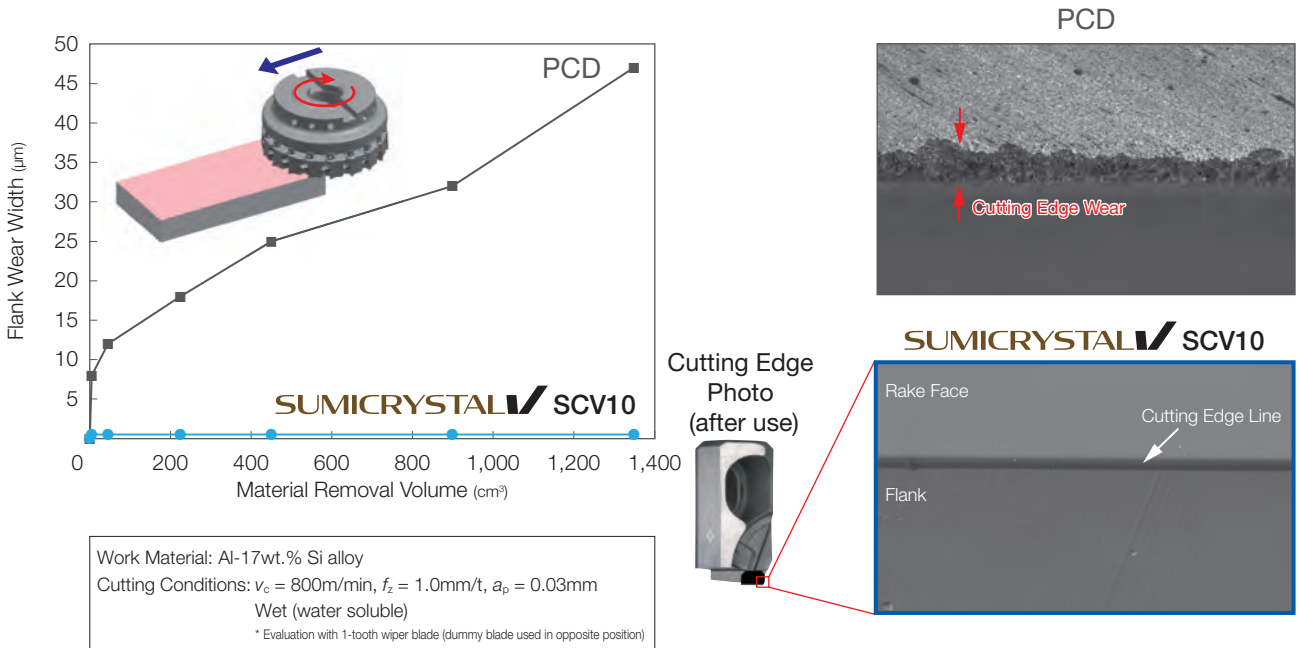

Long-term mirror finish with burrs suppressed and no flank wear progress

◆ Jet-black high-strength single-crystal diamond grade

Fracture resistance evaluation in aluminum alloy-ceramic composite machining

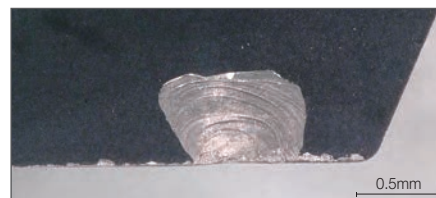
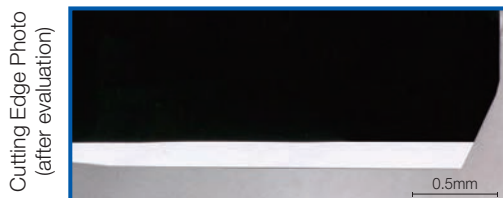
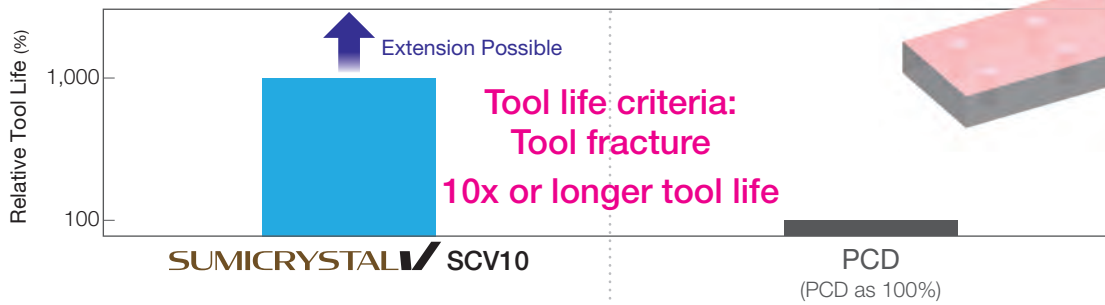

Work Material: Aluminum Alloy + Ceramic Composite
 Cutting Conditions: $v_c = 2,500\text{m/min}$, $f_z = 1.0\text{mm/t}$, $a_p = 0.03\text{mm}$
 Wet (water soluble)
 * Evaluation with 1-tooth wiper blade (dummy blade used in opposite position)

10x or more fracture resistance compared to PCD in finishing at low depth of cut (0.05 mm or less)



■ Features

DA1090 is a polycrystalline diamond grade with the highest diamond content, made by sintering coarse diamond particles at high density. High density and enhanced particle binding strength provide excellent wear and fracture resistance when machining cemented carbide and aluminum composite materials, enabling even more stable machining.

● Aluminum alloy and cast iron bi-metal machining is possible when used with ALNEX cutters

Achieving excellent performance by combining the grade's high wear resistance and fracture resistance with the GB type cutting edge design

SUMIDIA
DA1090

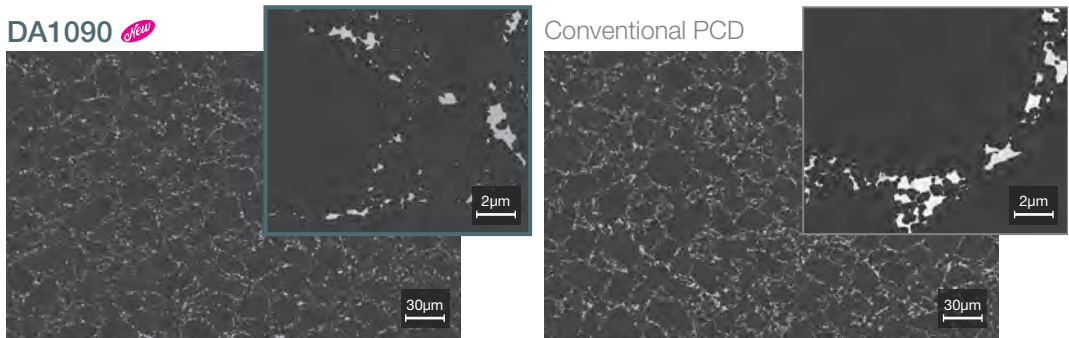

Realising high content and enhanced particle binding strength

*Black areas in image are diamond particles

■ Wear Resistance (DA1090)

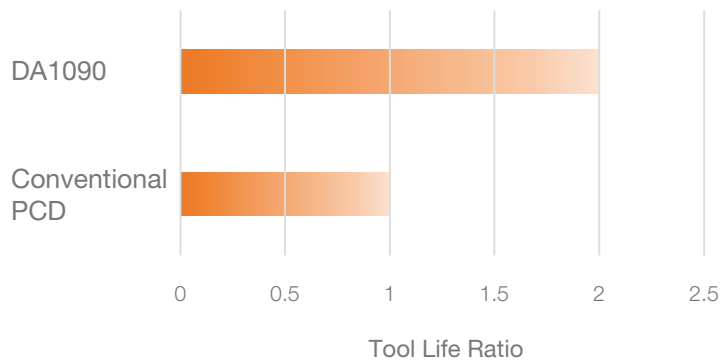
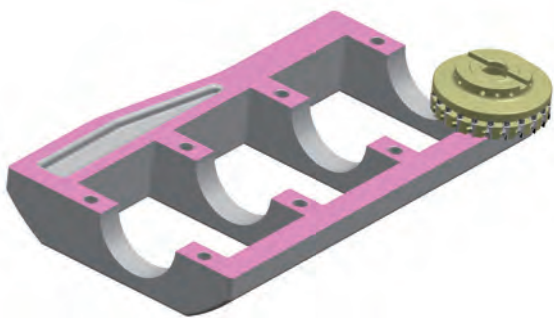

Work Material: ADC12 + FC250 (Lower Block)
 Tool: ANXA 16125R10 (ø125, 10 flutes)
 Blade: ANB1600R-GB (DA1090)
 Cutting Conditions: $v_c = 350\text{m/min}$, $f_z = 0.12\text{mm/rev}$,
 $a_p = 0.2\text{mm Wet}$

Improved wear resistance achieves twice the tool life of conventional PCD

Polycrystalline Diamond SUMIDIA DA1000/DA90/DA1090

Through the ideal combination of diamond particle size and binder, SUMIDIA DA1000/DA90/DA1090 possess various features and can be applied to all kinds of applications such as machining of aluminum alloy and cemented carbide.

■ Grade Characteristics

| Grade | Content (%) | Average grain size of diamond particles (μm) | Hardness HK (GPa) | TRS (GPa) | Features |
|--------|-------------|--|-------------------|-----------|---|
| DA1000 | 90 to 95 | Up to 0.5 | 50 to 60 | ≈ 2.60 | High-density sintered grade made of ultra-fine grain diamond that exhibits excellent wear and fracture resistance as well as edge sharpness. |
| DA90 | 90 to 95 | 50 | 50 to 65 | ≈ 1.10 | Grade in which coarse diamond grades are sintered. Shows high diamond content for excellent wear resistance. |
| DA1090 | 92 to 97 | Up to 50 | 55 to 70 | ≈ 1.30 | Grade in which coarse diamond grains are sintered at high density. Shows the highest diamond content for excellent wear resistance and fracture resistance. |

■ Application Range

| Work Material | | Applicable Grade | Example Parts |
|---------------|---|------------------|--|
| Aluminum | Sintered Aluminum, Wrought Aluminum Alloy | DA1000 | Piston Liners, Machine Parts, etc. |
| | Alloys for Die Casting | | Transmission Case, Oil Pan, Cylinder Block |
| | Alloys for Casting Low Si (≤12%) | | Cylinder Head |
| | Alloys for Casting High Si (>12%) | | Cylinder Block |
| Non-aluminum | Non-Ferrous Sintered Alloy | DA1000 | Bush |
| | Gunmetal, Carbon | | Connecting Rod |
| | Fe Combined | DA1090 | Cylinder Block, Bearing Cap |

CVD Single Crystal Diamond SCV10

With the high-strength single crystal diamond created through vapor phase synthesis technology, excellent wear resistance and a sharp cutting edge realize a burr-free mirror finish in aluminum alloy machining.

■ Work Material

| Grade | Work Material |
|-------|---|
| SCV10 | Aluminum Alloy, Copper Alloy Other Non-ferrous Sintered Alloys |

Precautions when Using W Type/WS Type Wiper Blades

■ W Type Setting

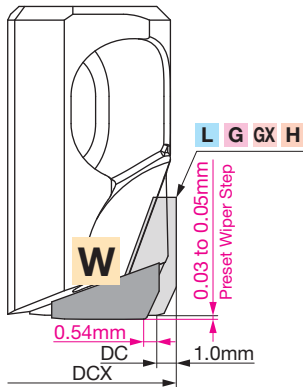

⚠ Precautions

In order to maintain cutter balance when using the W Type wiper blade, use a cutter with an even-number of cutting teeth and place another W Type wiper blade at the opposite teeth position.

■ WS Type Setting

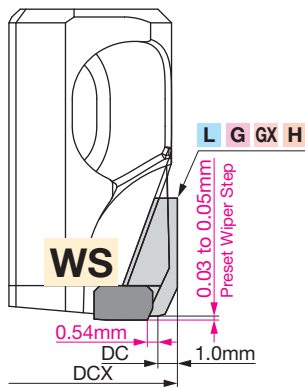

⚠ Precautions (For more details, refer to the instruction manual included with the product)

In order to maintain cutter balance when using the WS Type (SCV10 wiper blade), use a cutter with an even-number of cutting teeth and place another WS Type wiper blade (or dummy blade ANBD) at the opposite teeth position. * The dummy blade is dedicated for use with WS Type.

■ WS Type Recommended Feed Rate

| WS Cutting Edge Feed Rate per Tooth ^{*1} f_{zws} (mm/ t_{ws}) | $D \leq 0.5$ | $0.5 < D \leq 1.7$ | $1.7 < D$ |
|--|---------------|--------------------|------------|
| Burr-free Finish | ◎ Excellent | | Impossible |
| Mirror Finishing | ◎ Excellent | ○ Good | |
| Target Surface Roughness Ra (μm) | 0.015 to 0.05 | up to 0.6 | |

*1 Feed Rate per WS Cutting Edge Tooth f_{zws} Feed Rate per Tooth f_z

$$f_{zws}(\text{mm}/t_{ws}) = \frac{f_z \times (\text{Total No. of Teeth})^2}{(\text{WS Type No. of Teeth})^3}$$

$$f_z(\text{mm}/t) = \frac{\text{Feed Rate } v_f (\text{mm}/\text{min})}{\text{Spindle Speed } n (\text{min}^{-1}) \times (\text{Total No. of Teeth})}$$

*2 Total number of teeth includes dummy blade and wiper blade (WS Type).

*3 WS Type number of teeth does not include dummy blade.

MEMO

A large grid of dotted lines for writing a memo. The grid consists of 20 columns and 30 rows of small squares, providing a structured space for text entry.

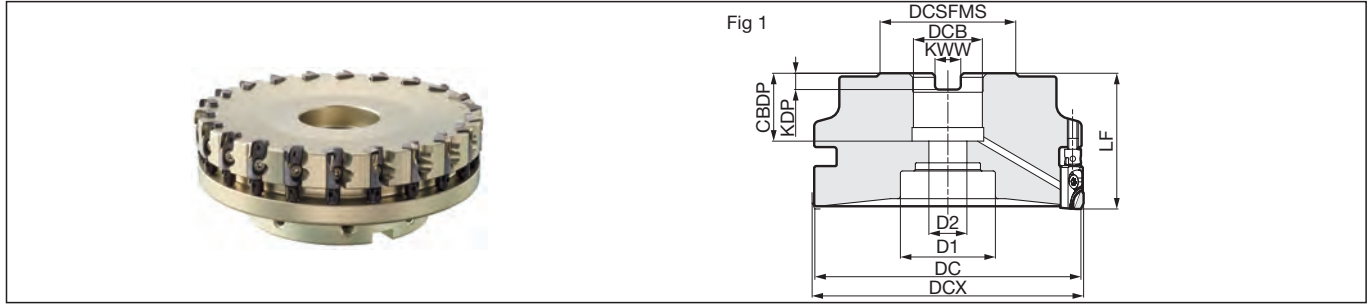

Body (Aluminum Alloy)

Dimensions (mm)

| Cat. No. | Stock | Max. Dia. | Dia. | Boss Dia. | Overall Length | Hole Dia. | Keyway Width | Keyway Depth | Mounting Depth | Bolt | Bolt | Number | Weight | Fig |
|----------------|-------|-----------|------|-----------|----------------|-----------|--------------|--------------|----------------|------|------|----------|--------|-----|
| | | DCX | DC | DCSFMS | LF | DCB | KWW | KDP | CBDP | D1 | D2 | of Teeth | (kg) | |
| Metric | | | | | | | | | | | | | | |
| ANXA 16080RS06 | ● | 80 | 78 | 50 | 50 | 27 | 12.4 | 7 | 22 | 35 | 14 | 6 | 0.5 | 1 |
| ANXA 16080RS10 | ● | 80 | 78 | 50 | 50 | 27 | 12.4 | 7 | 22 | 35 | 14 | 10 | 0.5 | 1 |
| ANXA 16080RS14 | ● | 80 | 78 | 50 | 50 | 27 | 12.4 | 7 | 22 | 35 | 14 | 14 | 0.5 | 1 |
| ANXA 16100RS08 | ● | 100 | 98 | 50 | 50 | 27 | 12.4 | 7 | 22 | 35 | 14 | 8 | 0.8 | 1 |
| ANXA 16100RS12 | ● | 100 | 98 | 50 | 50 | 27 | 12.4 | 7 | 22 | 35 | 14 | 12 | 0.8 | 1 |
| ANXA 16100RS18 | ● | 100 | 98 | 50 | 50 | 27 | 12.4 | 7 | 22 | 35 | 14 | 18 | 0.8 | 1 |
| ANXA 16125RS10 | ● | 125 | 123 | 50 | 50 | 27 | 12.4 | 7 | 22 | 35 | 14 | 10 | 1.2 | 1 |
| ANXA 16125RS14 | ● | 125 | 123 | 50 | 50 | 27 | 12.4 | 7 | 22 | 35 | 14 | 14 | 1.2 | 1 |
| ANXA 16125RS22 | ● | 125 | 123 | 50 | 50 | 27 | 12.4 | 7 | 22 | 35 | 14 | 22 | 1.3 | 1 |
| ANXA 16160RS12 | ● | 160 | 158 | 80 | 63 | 40 | 16.4 | 9 | 29 | 52 | 29 | 12 | 2.6 | 1 |
| ANXA 16160RS20 | ● | 160 | 158 | 80 | 63 | 40 | 16.4 | 9 | 29 | 52 | 29 | 20 | 2.6 | 1 |
| ANXA 16160RS28 | ● | 160 | 158 | 80 | 63 | 40 | 16.4 | 9 | 29 | 52 | 29 | 28 | 2.6 | 1 |
| Inch | | | | | | | | | | | | | | |
| ANXA 16080R06 | ● | 80 | 78 | 50 | 50 | 25.4 | 9.5 | 6 | 25 | 35 | 14 | 6 | 0.5 | 1 |
| ANXA 16080R10 | ● | 80 | 78 | 50 | 50 | 25.4 | 9.5 | 6 | 25 | 35 | 14 | 10 | 0.5 | 1 |
| ANXA 16080R14 | ● | 80 | 78 | 50 | 50 | 25.4 | 9.5 | 6 | 25 | 35 | 14 | 14 | 0.5 | 1 |
| ANXA 16100R08 | ● | 100 | 98 | 50 | 50 | 25.4 | 9.5 | 6 | 25 | 35 | 14 | 8 | 0.8 | 1 |
| ANXA 16100R12 | ● | 100 | 98 | 50 | 50 | 25.4 | 9.5 | 6 | 25 | 35 | 14 | 12 | 0.9 | 1 |
| ANXA 16100R18 | ● | 100 | 98 | 50 | 50 | 25.4 | 9.5 | 6 | 25 | 35 | 14 | 18 | 0.9 | 1 |
| ANXA 16125R10 | ● | 125 | 123 | 50 | 50 | 25.4 | 9.5 | 6 | 25 | 35 | 14 | 10 | 1.2 | 1 |
| ANXA 16125R14 | ● | 125 | 123 | 50 | 50 | 25.4 | 9.5 | 6 | 25 | 35 | 14 | 14 | 1.2 | 1 |
| ANXA 16125R22 | ● | 125 | 123 | 50 | 50 | 25.4 | 9.5 | 6 | 25 | 35 | 14 | 22 | 1.3 | 1 |
| ANXA 16160R12 | ● | 160 | 158 | 80 | 63 | 38.1 | 15.9 | 10 | 35.5 | 55 | 30 | 12 | 2.3 | 1 |
| ANXA 16160R20 | ● | 160 | 158 | 80 | 63 | 38.1 | 15.9 | 10 | 35.5 | 55 | 30 | 20 | 2.4 | 1 |
| ANXA 16160R28 | ● | 160 | 158 | 80 | 63 | 38.1 | 15.9 | 10 | 35.5 | 55 | 30 | 28 | 2.6 | 1 |

Blades are sold separately.

If using blades with corner radius (ANB1604R/ANB1608R), DC = DCX.

Weight indicated includes the weight with blades and other spare parts (excluding the center bolt).

All aluminum alloy cutter bodies from (DCX) ø80 to ø125 have similar bore diameter (DCB) (metric ø27/inch ø25.4).

Identification Code

ANX A 16 100 R S 18

Series Aluminum Alloy Body Blade Size Max. Dia. Feed Direction Metric Bore Number of Teeth

Spare Parts

| Applicable Cutter | Clamp Screw | Wrench | Adjustment Screw | Adjustment Wrench | Center Bolt | | |
|-------------------|-------------|----------|------------------|-------------------|-------------|-----|-------------|
| ANXA 16080R(S)○○ | BXA0310IP | TRXW10IP | HFJ | ANT | BXH1235-D33 | | |
| ANXA 16100R(S)○○ | | | | | | 2.0 | 50 |
| ANXA 16125R(S)○○ | | | | | | | |
| ANXA 16160R(S)○○ | | | | | | | BXH2036-D50 |

Recommended Tightening Torque (N-m)

The adjustment wrench (ANT) can also be used for height adjustment of the High-speed Cutter RF Type and High-efficiency Cutter HF Type.

Blades

Dimensions (mm)

| Grade Classification | | SUMIDIA | | | SUMICRYSTAL V | | | | | | |
|----------------------|------------------|---|------|----------------|---------------------|------------------|------------------|-------------------------------|-----|--|--|
| Applications | High-speed/Light | N | K | N | N | | | | | | |
| | General-purpose | N | K | N | | | | | | | |
| | Roughing | N | K | N | | | | | | | |
| Cat. No. | DA1000 | DA1090 New | DA90 | SCV10 | Cutting Edge Length | Corner Radius RE | Wiper Flat Shape | Applications | Fig | | |
| ANB 1600R-L | ● | | | — | 6.0 | — | Linear | Low Resistance | 1 | | |
| ANB 1600R-G | ● | | | — | 6.0 | — | Arc-Shaped | General-purpose | 1 | | |
| ANB 1600R-GB | | ● | ● | — | 6.0 | — | Arc-Shaped | Combined Milling ¹ | 1 | | |
| ANB 1600R-H | ● | | | — | 6.0 | — | Arc-Shaped | Strong Edge | 1 | | |
| ANB 1600R-GX | ● | | | — | 9.0 | — | Arc-Shaped | Long Edge | 2 | | |
| ANB 1604R | ● | | | — | 6.0 | 0.4 | Linear | Corner Radius | 3 | | |
| ANB 1608R | ● | | | — | 6.0 | 0.8 | Linear | Corner Radius | 3 | | |
| ANB 1600R-W | ● | | | — | — | — | Arc-Shaped | Wiper | 4 | | |
| ANB 1600R-WS | — | | | ● | — | — | Arc-Shaped | Wiper | 5 | | |
| ANBD | — | | | ● ² | — | — | — | Dummy Blade | 6 | | |

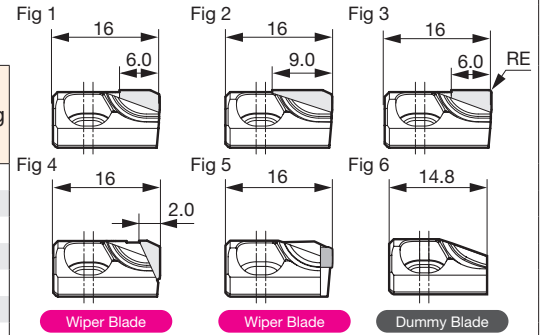

*1 Cast Iron/Aluminum Alloy *2 Dummy blade for use with WS type (cemented carbide), refer to P6 "Precautions when Using Wiper Blades" (Mounting Precautions).

Recommended Cutting Conditions

Si content of 12.6% or less

| ISO | Work Material | Hardness | Cutting Speed v_c (m/min) Min. - Optimum - Max. | Feed Rate f_z (mm/t) Min. - Optimum - Max. | Blade Grade |
|-----|----------------|----------|--|---|-----------------|
| N | Aluminum Alloy | — | 2,000 - 2,500 - 3,000 | 0.05 - 0.13 - 0.20 | DA1000 SCV10 |

Si content of over 12.6%

| ISO | Work Material | Hardness | Cutting Speed v_c (m/min) Min. - Optimum - Max. | Feed Rate f_z (mm/t) Min. - Optimum - Max. | Blade Grade |
|-----|----------------|----------|--|---|---------------------------|
| N | Aluminum Alloy | — | 400 - 600 - 800 | 0.05 - 0.13 - 0.20 | DA1000 DA1090 SCV10 |

Combined Milling of Cast Iron/Aluminum Alloy

| ISO | Work Material | Hardness | Cutting Speed v_c (m/min) Min. - Optimum - Max. | Feed Rate f_z (mm/t) Min. - Optimum - Max. | Blade Grade |
|--------|------------------------------|----------|--|---|-------------|
| K N | Cast Iron/ Aluminum Alloy | — | 300 - 400 - 500 | 0.05 - 0.13 - 0.20 | DA1090 |

Note The cutting conditions above are a guide. Actual conditions will need to be adjusted according to machine rigidity, work clamp rigidity, depth of cut and other factors.
For combined milling of cast iron/aluminum alloy, we recommend DA90.

Maximum Allowable Spindle Speed

| Cat. No. | n max (min ⁻¹) |
|----------------|------------------------------|
| ANXA 16080RS06 | 20,000 |
| ANXA 16080RS10 | 20,000 |
| ANXA 16080RS14 | 20,000 |
| ANXA 16100RS08 | 18,000 |
| ANXA 16100RS12 | 18,000 |
| ANXA 16100RS18 | 18,000 |
| ANXA 16125RS10 | 16,000 |
| ANXA 16125RS14 | 16,000 |
| ANXA 16125RS22 | 16,000 |
| ANXA 16160RS12 | 14,000 |
| ANXA 16160RS20 | 14,000 |
| ANXA 16160RS28 | 14,000 |
| ANXA 16080R06 | 20,000 |
| ANXA 16080R10 | 20,000 |
| ANXA 16080R14 | 20,000 |
| ANXA 16100R08 | 18,000 |
| ANXA 16100R12 | 18,000 |
| ANXA 16100R18 | 18,000 |
| ANXA 16125R10 | 16,000 |
| ANXA 16125R14 | 16,000 |
| ANXA 16125R22 | 16,000 |
| ANXA 16160R12 | 14,000 |
| ANXA 16160R20 | 14,000 |
| ANXA 16160R28 | 14,000 |

*The maximum allowable spindle speeds are set to prevent the inserts from dislodging by centrifugal force.

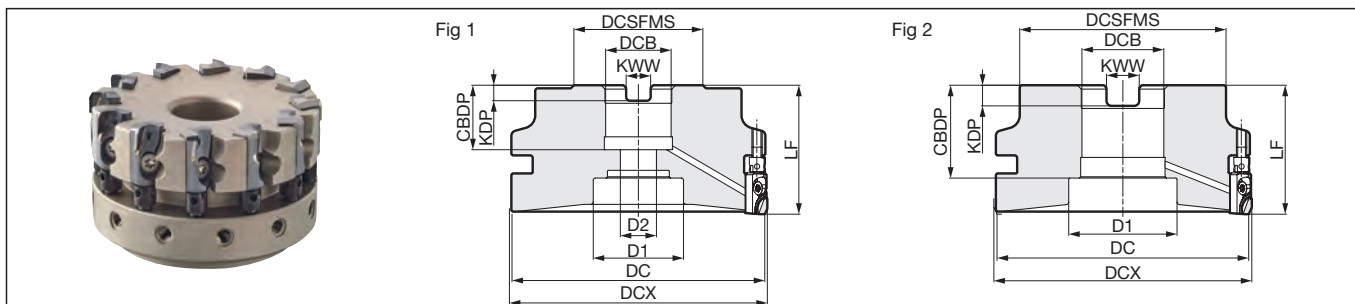

Body (Steel)

Dimensions (mm)

| | Cat. No. | Stock | Max. Dia. DCX | Dia. DC | Boss Dia. DCSFMS | Overall Length LF | Hole Dia. DCB | Keyway Width KWW | Keyway Depth KDP | Mounting Depth CDBP | Bolt D1 | Bolt D2 | Number of Teeth | Weight (kg) | Fig |
|----------------|----------------|-------|------------------|------------|---------------------|----------------------|------------------|---------------------|---------------------|------------------------|------------|------------|--------------------|----------------|-----|
| | | | | | | | | | | | | | | | |
| Metric | ANXS 16040RS04 | ● | 40 | 38 | 38.5 | 40 | 16 | 8.4 | 5.6 | 18 | 14 | 9 | 4 | 0.3 | 1 |
| | ANXS 16040RS06 | ● | 40 | 38 | 38.5 | 40 | 16 | 8.4 | 5.6 | 18 | 14 | 9 | 6 | 0.3 | 1 |
| | ANXS 16050RS04 | ● | 50 | 48 | 48.5 | 40 | 22 | 10.4 | 6.3 | 20 | 18 | 11 | 4 | 0.4 | 1 |
| | ANXS 16050RS06 | ● | 50 | 48 | 48.5 | 40 | 22 | 10.4 | 6.3 | 20 | 18 | 11 | 6 | 0.4 | 1 |
| | ANXS 16050RS09 | ● | 50 | 48 | 48.5 | 40 | 22 | 10.4 | 6.3 | 20 | 18 | 11 | 9 | 0.4 | 1 |
| | ANXS 16063RS06 | ● | 63 | 61 | 50 | 40 | 22 | 10.4 | 6.3 | 20 | 18 | 11 | 6 | 0.7 | 1 |
| | ANXS 16063RS08 | ● | 63 | 61 | 50 | 40 | 22 | 10.4 | 6.3 | 20 | 18 | 11 | 8 | 0.7 | 1 |
| | ANXS 16063RS12 | ● | 63 | 61 | 50 | 40 | 22 | 10.4 | 6.3 | 20 | 18 | 11 | 12 | 0.7 | 1 |
| | ANXS 16080RS06 | ● | 80 | 78 | 50 | 50 | 27 | 12.4 | 7 | 22 | 35 | 14 | 6 | 1.2 | 1 |
| | ANXS 16080RS10 | ● | 80 | 78 | 50 | 50 | 27 | 12.4 | 7 | 22 | 35 | 14 | 10 | 1.2 | 1 |
| | ANXS 16080RS14 | ● | 80 | 78 | 50 | 50 | 27 | 12.4 | 7 | 22 | 35 | 14 | 14 | 1.2 | 1 |
| | ANXS 16100RS08 | ● | 100 | 98 | 80 | 50 | 32 | 14.4 | 8 | 32 | 46 | — | 8 | 1.9 | 2 |
| | ANXS 16100RS12 | ● | 100 | 98 | 80 | 50 | 32 | 14.4 | 8 | 32 | 46 | — | 12 | 2.0 | 2 |
| | ANXS 16100RS18 | ● | 100 | 98 | 80 | 50 | 32 | 14.4 | 8 | 32 | 46 | — | 18 | 2.0 | 2 |
| | ANXS 16125RS10 | ● | 125 | 123 | 80 | 63 | 40 | 16.4 | 9 | 29 | 52 | 29 | 10 | 3.8 | 1 |
| ANXS 16125RS14 | ● | 125 | 123 | 80 | 63 | 40 | 16.4 | 9 | 29 | 52 | 29 | 14 | 3.9 | 1 | |
| ANXS 16125RS22 | ● | 125 | 123 | 80 | 63 | 40 | 16.4 | 9 | 29 | 52 | 29 | 22 | 3.9 | 1 | |
| Inch | ANXS 16063R06 | ● | 63 | 61 | 50 | 50 | 25.4 | 9.5 | 6 | 25 | 20 | 14 | 6 | 0.9 | 1 |
| | ANXS 16063R08 | ● | 63 | 61 | 50 | 50 | 25.4 | 9.5 | 6 | 25 | 20 | 14 | 8 | 0.9 | 1 |
| | ANXS 16063R12 | ● | 63 | 61 | 50 | 50 | 25.4 | 9.5 | 6 | 25 | 20 | 14 | 12 | 0.9 | 1 |
| | ANXS 16080R06 | ● | 80 | 78 | 50 | 50 | 25.4 | 9.5 | 6 | 25 | 35 | 14 | 6 | 1.2 | 1 |
| | ANXS 16080R10 | ● | 80 | 78 | 50 | 50 | 25.4 | 9.5 | 6 | 25 | 35 | 14 | 10 | 1.2 | 1 |
| | ANXS 16080R14 | ● | 80 | 78 | 50 | 50 | 25.4 | 9.5 | 6 | 25 | 35 | 14 | 14 | 1.2 | 1 |
| | ANXS 16100R08 | ● | 100 | 98 | 80 | 50 | 31.75 | 12.7 | 8 | 36 | 42 | — | 8 | 1.9 | 2 |
| | ANXS 16100R12 | ● | 100 | 98 | 80 | 50 | 31.75 | 12.7 | 8 | 36 | 42 | — | 12 | 2.0 | 2 |
| | ANXS 16100R18 | ● | 100 | 98 | 80 | 50 | 31.75 | 12.7 | 8 | 36 | 42 | — | 18 | 2.0 | 2 |
| | ANXS 16125R10 | ● | 125 | 123 | 80 | 63 | 38.1 | 15.9 | 10 | 35.5 | 52 | 29 | 10 | 3.9 | 1 |
| | ANXS 16125R14 | ● | 125 | 123 | 80 | 63 | 38.1 | 15.9 | 10 | 35.5 | 52 | 29 | 14 | 3.9 | 1 |
| | ANXS 16125R22 | ● | 125 | 123 | 80 | 63 | 38.1 | 15.9 | 10 | 35.5 | 52 | 29 | 22 | 3.9 | 1 |

Blades are sold separately.

If using blades with corner radius (ANB1604R/ANB1608R), DC = DCX.

Weight indicated includes the weight with blades and other spare parts (excluding the center bolt).

Identification Code

ANX S 16 100 R S 18

Series Steel Body Blade Size Max. Dia. Feed Direction Metric Bore Number of Teeth

Spare Parts

| Applicable Cutter | Clamp Screw | Wrench | Adjustment Screw | Adjustment Wrench | Center Bolt |
|-------------------|----------------------|----------|------------------|-------------------|------------------------|
| | (N·m) | | | | (N·m) |
| ANXS 16040RS○○ | | | | | BXH0825-D13 15 |
| ANXS 16050RS○○ | | | | | BXH1030-D16 25 |
| ANXS 16063RS○○ | BXA0310IP 2.0 | TRXW10IP | HFJ | ANT | BXH1235-D33 50 |
| ANXS 16080RS○○ | | | | | BXH1635-D40 100 |
| ANXS 16100RS○○ | | | | | BXH2036-D50 200 |
| ANXS 16125RS○○ | | | | | BXH1235-D18 40 |
| ANXS 16063R○○ | | | | | BXH1235-D33 50 |
| ANXS 16080R○○ | BXA0310IP 2.0 | TRXW10IP | HFJ | ANT | BXH1635-D40 100 |
| ANXS 16100R○○ | | | | | BXH2036-D50 200 |
| ANXS 16125R○○ | | | | | |

(N·m) Recommended Tightening Torque (N·m)

The adjustment wrench (ANT) can also be used for height adjustment of the High-speed Cutter RF Type and High-efficiency Cutter HF Type.

● mark: Standard stocked item

Blades

Dimensions (mm)

| Grade Classification | | SUMIDIA | | | SUMICRYSTAL V | | | | | |
|----------------------|------------------|--------------------------------------|---|------------------------------------|--------------------------------------|---------------------|------------------|------------------|-------------------------------|-----|
| Applications | High-speed/Light | N | K | N | N | | | | | |
| | General-purpose | N | K | N | | | | | | |
| | Roughing | N | K | N | | | | | | |
| Cat. No. | | DA1000 | DA1090 New | DA90 | SCV10 | Cutting Edge Length | Corner Radius RE | Wiper Flat Shape | Applications | Fig |
| ANB 1600R-L | | ● | | | — | 6.0 | — | Linear | Low Resistance | 1 |
| ANB 1600R-G | | ● | | | — | 6.0 | — | Arc-Shaped | General-purpose | 1 |
| ANB 1600R-GB | | | ● | ● | — | 6.0 | — | Arc-Shaped | Combined Milling ¹ | 1 |
| ANB 1600R-H | | ● | — | — | — | 6.0 | — | Arc-Shaped | Strong Edge | 1 |
| ANB 1600R-GX | | ● | | | — | 9.0 | — | Arc-Shaped | Long Edge | 2 |
| ANB 1604R | | ● | | | — | 6.0 | 0.4 | Linear | Corner Radius | 3 |
| ANB 1608R | | ● | | | — | 6.0 | 0.8 | Linear | Corner Radius | 3 |
| ANB 1600R-W | | ● | | | — | — | — | Arc-Shaped | Wiper | 4 |
| ANB 1600R-WS | | — | — | — | ● | — | — | Arc-Shaped | Wiper | 5 |
| ANBD | | — | — | — | ● ² | — | — | — | Dummy Blade | 6 |

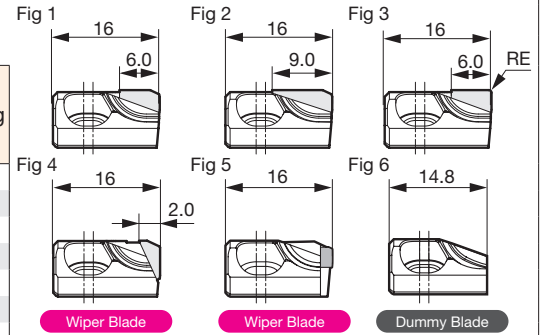

*1 Cast Iron/Aluminum Alloy *2 Dummy blade for use with WS type (cemented carbide), refer to P6 "Precautions when Using Wiper Blades" (Mounting Precautions).

Recommended Cutting Conditions

Si content of 12.6% or less

| ISO | Work Material | Hardness | Cutting Speed v_c (m/min) Min. - Optimum - Max. | Feed Rate f_z (mm/t) Min. - Optimum - Max. | Blade Grade |
|--------------------------------------|----------------|----------|--|---|-----------------|
| N | Aluminum Alloy | — | 2,000 - 2,500 - 3,000 | 0.05 - 0.13 - 0.20 | DA1000 SCV10 |

Si content of over 12.6%

| ISO | Work Material | Hardness | Cutting Speed v_c (m/min) Min. - Optimum - Max. | Feed Rate f_z (mm/t) Min. - Optimum - Max. | Blade Grade |
|--------------------------------------|----------------|----------|--|---|---------------------------|
| N | Aluminum Alloy | — | 400 - 600 - 800 | 0.05 - 0.13 - 0.20 | DA1000 DA1090 SCV10 |

Combined Milling of Cast Iron/Aluminum Alloy

| ISO | Work Material | Hardness | Cutting Speed v_c (m/min) Min. - Optimum - Max. | Feed Rate f_z (mm/t) Min. - Optimum - Max. | Blade Grade |
|--|------------------------------|----------|--|---|-------------|
| K N | Cast Iron/ Aluminum Alloy | — | 300 - 400 - 500 | 0.05 - 0.13 - 0.20 | DA1090 |

Note The cutting conditions above are a guide. Actual conditions will need to be adjusted according to machine rigidity, work clamp rigidity, depth of cut and other factors.
For combined milling of cast iron/aluminum alloy, we recommend DA90.

Maximum Allowable Spindle Speed

| Cat. No. | n max (min ⁻¹) |
|----------------|------------------------------|
| ANXS 16040RS04 | 25,000 |
| ANXS 16040RS06 | 25,000 |
| ANXS 16050RS04 | 25,000 |
| ANXS 16050RS06 | 25,000 |
| ANXS 16050RS09 | 25,000 |
| ANXS 16063RS06 | 22,000 |
| ANXS 16063RS08 | 22,000 |
| ANXS 16063RS12 | 22,000 |
| ANXS 16080RS06 | 20,000 |
| ANXS 16080RS10 | 20,000 |
| ANXS 16080RS14 | 20,000 |
| ANXS 16100RS08 | 18,000 |
| ANXS 16100RS12 | 18,000 |
| ANXS 16100RS18 | 18,000 |
| ANXS 16125RS10 | 16,000 |
| ANXS 16125RS14 | 16,000 |
| ANXS 16125RS22 | 16,000 |
| ANXS 16063R06 | 22,000 |
| ANXS 16063R08 | 22,000 |
| ANXS 16063R12 | 22,000 |
| ANXS 16080R06 | 20,000 |
| ANXS 16080R10 | 20,000 |
| ANXS 16080R14 | 20,000 |
| ANXS 16100R08 | 18,000 |
| ANXS 16100R12 | 18,000 |
| ANXS 16100R18 | 18,000 |
| ANXS 16125R10 | 16,000 |
| ANXS 16125R14 | 16,000 |
| ANXS 16125R22 | 16,000 |

*The maximum allowable spindle speeds are set to prevent the inserts from dislodging by centrifugal force.

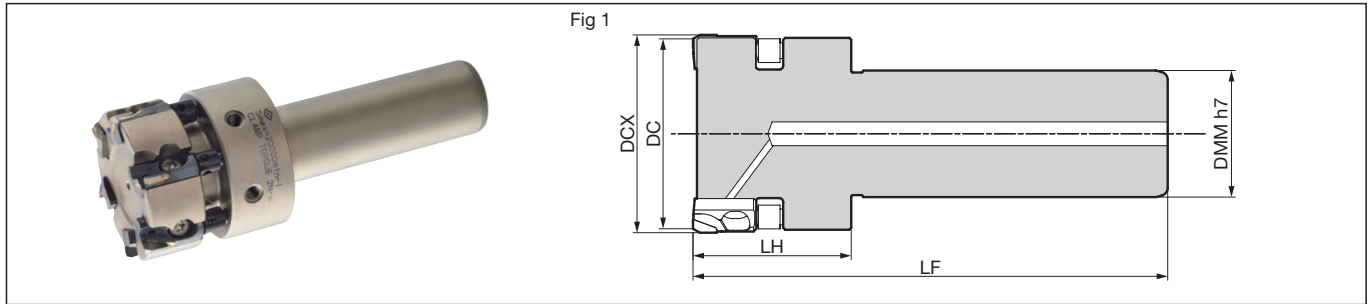

Body (Steel)

Dimensions (mm)

| Cat. No. | Stock | Max. Dia. DCX | Dia. DC | Shank Dia. DMM | Head LH | Overall Length LF | Number of Teeth | Weight (kg) | Fig |
|---------------|-------|---------------|---------|----------------|---------|-------------------|-----------------|-------------|-----|
| ANXS 16025E02 | ● | 25 | 23 | 20 | 35 | 95 | 2 | 0.2 | 1 |
| ANXS 16030E03 | ● | 30 | 28 | 20 | 35 | 95 | 3 | 0.3 | 1 |
| ANXS 16030E04 | ● | 30 | 28 | 20 | 35 | 95 | 4 | 0.3 | 1 |
| ANXS 16032E03 | ● | 32 | 30 | 20 | 35 | 95 | 3 | 0.3 | 1 |
| ANXS 16032E04 | ● | 32 | 30 | 20 | 35 | 95 | 4 | 0.3 | 1 |
| ANXS 16040E04 | ● | 40 | 38 | 20 | 40 | 100 | 4 | 0.4 | 1 |
| ANXS 16040E06 | ● | 40 | 38 | 20 | 40 | 100 | 6 | 0.5 | 1 |
| ANXS 16050E04 | ● | 50 | 48 | 32 | 40 | 120 | 4 | 1.0 | 1 |
| ANXS 16050E06 | ● | 50 | 48 | 32 | 40 | 120 | 6 | 1.0 | 1 |
| ANXS 16050E09 | ● | 50 | 48 | 32 | 40 | 120 | 9 | 1.0 | 1 |

Blades are sold separately.

If using blades with corner radius (ANB1604R/ANB1608R), DC = DCX.

Weight indicated includes the weight with blades and other spare parts.

Identification Code

ANX S 16 032 E 04

Series Steel Body Blade Size Max. Dia. Shank Type Number of Teeth

Spare Parts

| Clamp Screw | Wrench | Adjustment Screw | Adjustment Wrench |
|-------------|--------------|------------------|-------------------|
| | | | |
| BXA0310IP | 2.0 TRXW10IP | HFJ | ANT |

Recommended Tightening Torque (N-m)

The adjustment wrench (ANT) can also be used for height adjustment of the High-speed Cutter RF Type and High-efficiency Cutter HF Type.

Blades

Dimensions (mm)

| Grade Classification | | SUMIDIA | | | SUMICRYSTAL V | | | | | |
|----------------------|------------------|--|------|----------------|---------------------|------------------|------------------|-------------------------------|-----|--|
| Applications | High-speed/Light | N | K | N | N | | | | | |
| | General-purpose | N | K | N | N | | | | | |
| | Roughing | N | K | N | N | | | | | |
| Cat. No. | DA1000 | DA1090 New | DA90 | SCV10 | Cutting Edge Length | Corner Radius RE | Wiper Flat Shape | Applications | Fig | |
| ANB 1600R-L | ● | | | — | 6.0 | — | Linear | Low Resistance | 1 | |
| ANB 1600R-G | ● | | | — | 6.0 | — | Arc-Shaped | General-purpose | 1 | |
| ANB 1600R-GB | | ● | ● | — | 6.0 | — | Arc-Shaped | Combined Milling ¹ | 1 | |
| ANB 1600R-H | ● | | | — | 6.0 | — | Arc-Shaped | Strong Edge | 1 | |
| ANB 1600R-GX | ● | | | — | 9.0 | — | Arc-Shaped | Long Edge | 2 | |
| ANB 1604R | ● | | | — | 6.0 | 0.4 | Linear | Corner Radius | 3 | |
| ANB 1608R | ● | | | — | 6.0 | 0.8 | Linear | Corner Radius | 3 | |
| ANB 1600R-W | ● | | | — | — | — | Arc-Shaped | Wiper | 4 | |
| ANB 1600R-WS | — | — | — | ● | — | — | Arc-Shaped | Wiper | 5 | |
| ANBD | — | — | — | ● ² | — | — | — | Dummy Blade | 6 | |

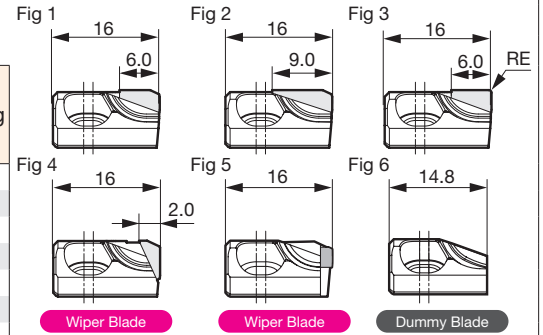

*1 Cast Iron/Aluminum Alloy *2 Dummy blade for use with WS type (cemented carbide), refer to P6 "Precautions when Using Wiper Blades" (Mounting Precautions).

Recommended Cutting Conditions

Si content of 12.6% or less

| ISO | Work Material | Hardness | Cutting Speed v_c (m/min) Min. - Optimum - Max. | Feed Rate f_z (mm/t) Min. - Optimum - Max. | Blade Grade |
|-----|----------------|----------|--|---|-----------------|
| N | Aluminum Alloy | — | 2,000 - 2,500 - 3,000 | 0.05 - 0.13 - 0.20 | DA1000 SCV10 |

Si content of over 12.6%

| ISO | Work Material | Hardness | Cutting Speed v_c (m/min) Min. - Optimum - Max. | Feed Rate f_z (mm/t) Min. - Optimum - Max. | Blade Grade |
|-----|----------------|----------|--|---|---------------------------|
| N | Aluminum Alloy | — | 400 - 600 - 800 | 0.05 - 0.13 - 0.20 | DA1000 DA1090 SCV10 |

Combined Milling of Cast Iron/Aluminum Alloy

| ISO | Work Material | Hardness | Cutting Speed v_c (m/min) Min. - Optimum - Max. | Feed Rate f_z (mm/t) Min. - Optimum - Max. | Blade Grade |
|--------|------------------------------|----------|--|---|-------------|
| K N | Cast Iron/ Aluminum Alloy | — | 300 - 400 - 500 | 0.05 - 0.13 - 0.20 | DA1090 |

Note The cutting conditions above are a guide. Actual conditions will need to be adjusted according to machine rigidity, work clamp rigidity, depth of cut and other factors.
For combined milling of cast iron/aluminum alloy, we recommend DA90.

Maximum Allowable Spindle Speed

| Cat. No. | n max (min ⁻¹) |
|---------------|------------------------------|
| ANXS 16025E02 | 10,000 |
| ANXS 16030E03 | 10,000 |
| ANXS 16030E04 | 10,000 |
| ANXS 16032E03 | 10,000 |
| ANXS 16032E04 | 10,000 |
| ANXS 16040E04 | 10,000 |
| ANXS 16040E06 | 10,000 |
| ANXS 16050E04 | 10,000 |
| ANXS 16050E06 | 10,000 |
| ANXS 16050E09 | 10,000 |

*The maximum allowable spindle speeds are set to prevent the inserts from dislodging by centrifugal force.

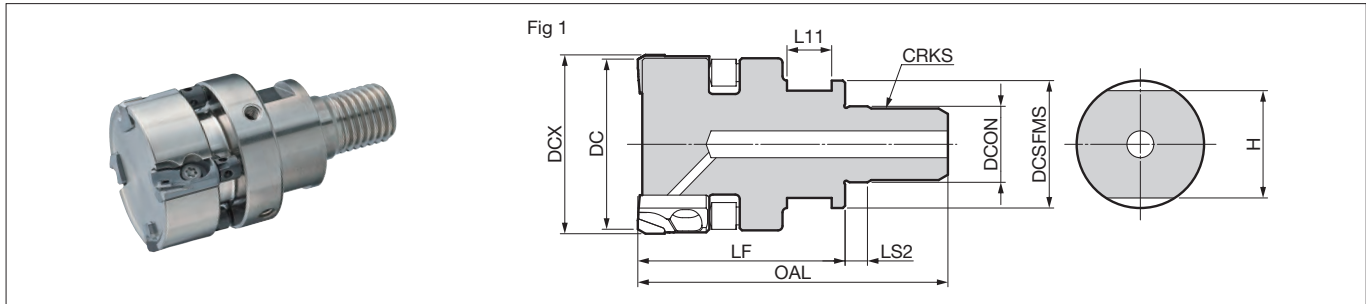

Body (Steel)

Dimensions (mm)

| Cat. No. | Stock | Max. Dia. | Dia. | Boss | Mounting Dia. | Screw | Overall Length | Effective Length | Neck | Flat | Width | Number of Teeth | Weight (kg) | Fig | |
|----------|------------------|-----------|------|--------|---------------|-------|----------------|------------------|------|------|-------|-----------------|-------------|-----|---|
| | | DCX | DC | DCSFMS | DCON | CRKS | OAL | LF | LS2 | L11 | H | | | | |
| Metric | ANXS 16025M12Z02 | ● | 25 | 23 | 23 | 12.5 | M12 | 61 | 40 | 5 | 10 | 19 | 2 | 0.1 | 1 |
| | ANXS 16030M16Z03 | ● | 30 | 28 | 28.5 | 17.0 | M16 | 70 | 47 | 5 | 10 | 24 | 3 | 0.2 | 1 |
| | ANXS 16030M16Z04 | ● | 30 | 28 | 28.5 | 17.0 | M16 | 70 | 47 | 5 | 10 | 24 | 4 | 0.2 | 1 |
| | ANXS 16032M16Z03 | ● | 32 | 30 | 28.5 | 17.0 | M16 | 70 | 47 | 5 | 10 | 24 | 3 | 0.3 | 1 |
| | ANXS 16032M16Z04 | ● | 32 | 30 | 28.5 | 17.0 | M16 | 70 | 47 | 5 | 10 | 24 | 4 | 0.3 | 1 |
| | ANXS 16040M16Z04 | ● | 40 | 38 | 28.5 | 17.0 | M16 | 70 | 47 | 5 | 10 | 24 | 4 | 0.4 | 1 |
| | ANXS 16040M16Z06 | ● | 40 | 38 | 28.5 | 17.0 | M16 | 70 | 47 | 5 | 10 | 24 | 6 | 0.4 | 1 |

Blades are sold separately.

If using blades with corner radius (ANB1604R/ANB1608R), DC = DCX.

Weight indicated includes the weight with blades and other spare parts.

Identification Code

ANX S 16 032 M16 Z03

Series Steel Body Blade Size Max. Dia. Screw Size Number of Teeth

Spare Parts

| Clamp Screw | Wrench | Adjustment Screw | Adjustment Wrench |
|-------------|--------|------------------|-------------------|
| | | | |
| BXA0310IP | 2.0 | TRXW10IP | HFJ ANT |

Recommended Tightening Torque (N·m)

The adjustment wrench (ANT) can also be used for height adjustment of the High-speed Cutter RF Type and High-efficiency Cutter HF Type.

Blades

Dimensions (mm)

| Grade Classification | | SUMIDIA | | | SUMICRYSTAL V | | | | | |
|----------------------|------------------|---------|---|------|----------------|---------------------|------------------|------------------|-------------------------------|-----|
| Applications | High-speed/Light | N | K | N | N | | | | | |
| | General-purpose | N | K | N | | | | | | |
| | Roughing | N | K | N | | | | | | |
| Cat. No. | | DA1000 | DA1090 New | DA90 | SCV10 | Cutting Edge Length | Corner Radius RE | Wiper Flat Shape | Applications | Fig |
| ANB 1600R-L | | ● | | | | 6.0 | — | Linear | Low Resistance | 1 |
| ANB 1600R-G | | ● | | | | 6.0 | — | Arc-Shaped | General-purpose | 1 |
| ANB 1600R-GB | | | ● | | | 6.0 | — | Arc-Shaped | Combined Milling ¹ | 1 |
| ANB 1600R-H | | ● | | | | 6.0 | — | Arc-Shaped | Strong Edge | 1 |
| ANB 1600R-GX | | ● | | | | 9.0 | — | Arc-Shaped | Long Edge | 2 |
| ANB 1604R | | ● | | | | 6.0 | 0.4 | Linear | Corner Radius | 3 |
| ANB 1608R | | ● | | | | 6.0 | 0.8 | Linear | Corner Radius | 3 |
| ANB 1600R-W | | ● | | | | — | — | Arc-Shaped | Wiper | 4 |
| ANB 1600R-WS | | | | | ● | — | — | Arc-Shaped | Wiper | 5 |
| ANBD | | | | | ● ² | — | — | — | Dummy Blade | 6 |

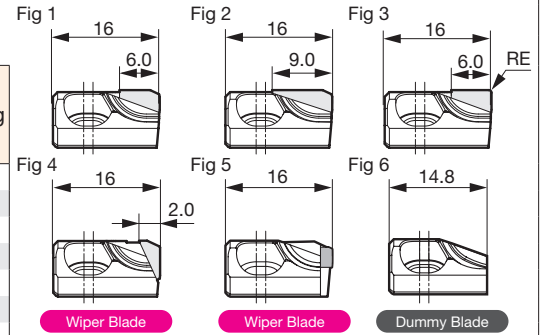

*1 Cast Iron/Aluminum Alloy *2 Dummy blade for use with WS type (cemented carbide), refer to P6 "Precautions when Using Wiper Blades" (Mounting Precautions).

Recommended Cutting Conditions

Si content of 12.6% or less

| ISO | Work Material | Hardness | Cutting Speed v_c (m/min) Min. - Optimum - Max. | Feed Rate f_z (mm/t) Min. - Optimum - Max. | Blade Grade |
|-----|----------------|----------|--|---|-----------------|
| N | Aluminum Alloy | — | 2,000 - 2,500 - 3,000 | 0.05 - 0.13 - 0.20 | DA1000 SCV10 |

Si content of over 12.6%

| ISO | Work Material | Hardness | Cutting Speed v_c (m/min) Min. - Optimum - Max. | Feed Rate f_z (mm/t) Min. - Optimum - Max. | Blade Grade |
|-----|----------------|----------|--|---|---------------------------|
| N | Aluminum Alloy | — | 400 - 600 - 800 | 0.05 - 0.13 - 0.20 | DA1000 DA1090 SCV10 |

Combined Milling of Cast Iron/Aluminum Alloy

| ISO | Work Material | Hardness | Cutting Speed v_c (m/min) Min. - Optimum - Max. | Feed Rate f_z (mm/t) Min. - Optimum - Max. | Blade Grade |
|--------|------------------------------|----------|--|---|-------------|
| K N | Cast Iron/ Aluminum Alloy | — | 300 - 400 - 500 | 0.05 - 0.13 - 0.20 | DA1090 |

Note The cutting conditions above are a guide. Actual conditions will need to be adjusted according to machine rigidity, work clamp rigidity, depth of cut and other factors.
For combined milling of cast iron/aluminum alloy, we recommend DA90.

Maximum Allowable Spindle Speed

| Cat. No. | n max (min ⁻¹) |
|------------------|------------------------------|
| ANXS 16025M12Z02 | 10,000 |
| ANXS 16030M16Z03 | 10,000 |
| ANXS 16030M16Z04 | 10,000 |
| ANXS 16032M16Z03 | 10,000 |
| ANXS 16032M16Z04 | 10,000 |
| ANXS 16040M16Z04 | 10,000 |
| ANXS 16040M16Z06 | 10,000 |

*The maximum allowable spindle speeds are set to prevent the inserts from dislodging by centrifugal force.

Special Arbors

■ BBT Integrated Type - SEC-Modular Tools Special Arbors

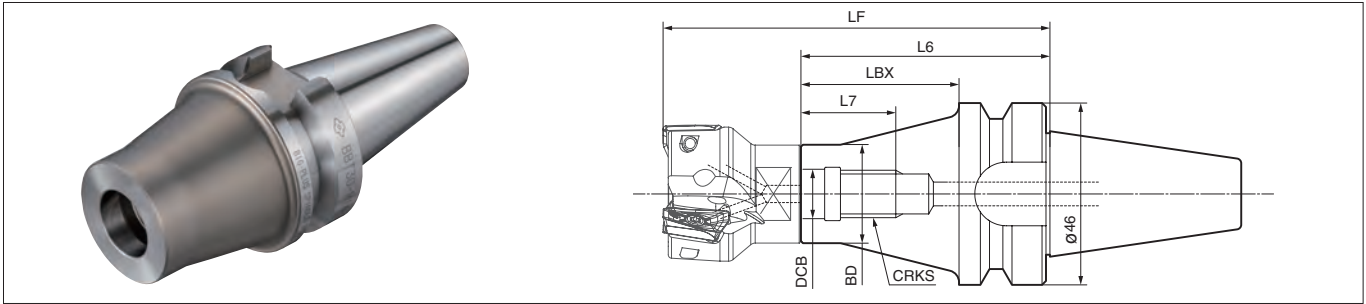

■ BBT Integrated Arbor

| Cat. No. | Stock | Screw CRKS | Dimensions (mm) | | | | | | |
|---------------------|-------|---------------|------------------|---------------------|---------------------|---------------|--------------------|------------------------------|-----------------|
| | | | Hole Dia. DCB | External Dia. BD | Body Overhang L6 | Length LBX | Thread Depth L7 | Overhang LF ^{*1} | Coolant Hole |
| BBT30-M12-40 | ● | M12 | 12.5 | 24.9 | 62 | 40 | 22 | 97 | Yes |
| BBT30-M16-35 | ● | M16 | 17 | 31.9 | 57 | 35 | 24 | 97 | Yes |

*1: Overhang length for LF is with head mounted.
* Can also be used with BT30 spindle machines.

■ SEC-Modular Tools - Special Arbors (Carbide Arbor/Steel Arbor)

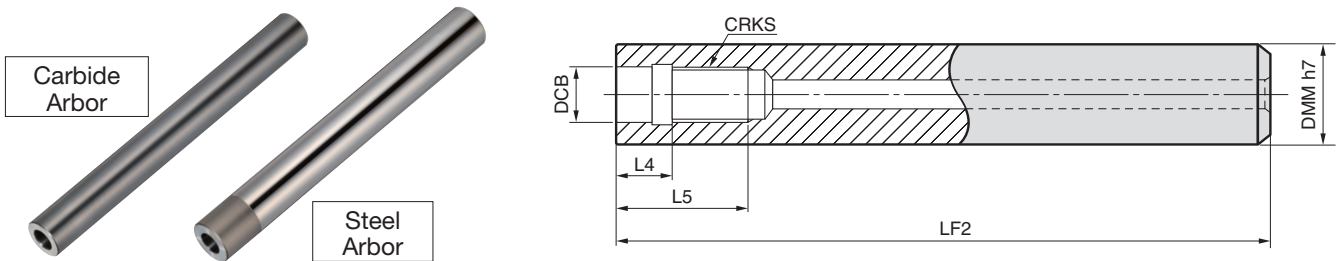

■ Carbide Arbors

| Cat. No. | Stock | Screw CRKS | Dimensions (mm) | | | | | |
|---------------------|-------|---------------|------------------|--------------|-----------------------|-------------|--------------------|-----------------------------------|
| | | | Hole Dia. DCB | Shank DMM | Overall Length LF2 | Depth L4 | Thread Depth L5 | Set Dimension LF ^{*2} |
| MA23M12L200C | ● | M12 | 12.5 | 23 | 200 | 10 | 22 | 235 |
| MA23M12L250C | ● | M12 | 12.5 | 23 | 250 | 10 | 22 | 285 |
| MA25M12L200C | ● | M12 | 12.5 | 25 | 200 | 10 | 22 | 235 |
| MA25M12L250C | ● | M12 | 12.5 | 25 | 250 | 10 | 22 | 285 |
| MA28M16L200C | ● | M16 | 17.0 | 28 | 200 | 10 | 24 | 240 |
| MA28M16L300C | ● | M16 | 17.0 | 28 | 300 | 10 | 24 | 340 |
| MA32M16L200C | ● | M16 | 17.0 | 32 | 200 | 10 | 24 | 240 |
| MA32M16L300C | ● | M16 | 17.0 | 32 | 300 | 10 | 24 | 340 |

■ Steel Arbors

| Cat. No. | Stock | Screw CRKS | Dimensions (mm) | | | | | |
|---------------------|-------|---------------|------------------|--------------|-----------------------|-------------|--------------------|-----------------------------------|
| | | | Hole Dia. DCB | Shank DMM | Overall Length LF2 | Depth L4 | Thread Depth L5 | Set Dimension LF ^{*2} |
| MA25M12L200S | ● | M12 | 12.5 | 25 | 200 | 10 | 22 | 235 |
| MA32M16L200S | ● | M16 | 17.0 | 32 | 200 | 10 | 24 | 240 |

■ Cat. No. Identification Table

| | | | | |
|-----------|------------|---------------------|----------------------|---|
| MA | 15 | M08 | L120 | C |
| Series | Shank Dia. | Mounting Screw Size | Arbor Overall Length | Arbor Materials (C: Carbide S: Steel) |

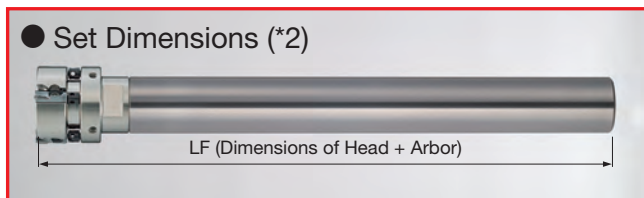

* Take note when tightening the head.

- When mounting the head to an arbor, follow the standard tightening torque in the table below.
- Check the mounting screw size for the head and arbor beforehand.
- Refer to the ■ Body table on P14 for the "Tool Dimensions" below.

| Screw Size | Regulated Tightening Torque (N·m) |
|------------|-----------------------------------|
| M12 | 60 |
| M16 | 80 |

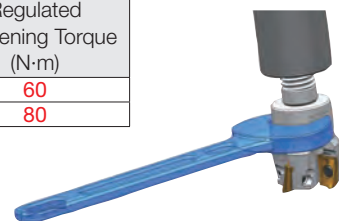



Application Example

| Aluminum Alloy ADC12 Engine Component | | Sumitomo | Comp's |
|---|------------------|---|----------------------------------|
| Vertical Machining Center HSK63A  | Tool | ANXS16063RS12 | PCD Cutter |
| | Grade | DA1000 | — |
| | Blade Type | G | — |
| | Cutter Dia. (mm) | 63 | 63 |
| | Number of Teeth | 12 | 6 |
| | vc (m/min) | 1,583 | 1,583 |
| | vf (mm/min) | 6,432 | 3,216 |
| | fz (mm/t) | 0.067 | 0.067 |
| | ap (mm) | 1 | 1 |
| | ae (mm) | — | — |
| | Coolant | Wet (External Coolant Supply) | Wet (External Coolant Supply) |
| | Results | Doubled machining efficiency with increased number of teeth Tool life extended 2.3x, burrs reduced | |

| Aluminum Alloy ADC12 Engine Component | | Sumitomo | — |
|--|------------------|---|---|
| Vertical Machining Center BT50  | Tool | ANXS16050E09 | — |
| | Grade | DA1000 | — |
| | Blade Type | R0.4 | — |
| | Cutter Dia. (mm) | 50 | — |
| | Number of Teeth | 9 | — |
| | vc (m/min) | 942 | — |
| | vf (mm/min) | 2,700 | — |
| | fz (mm/t) | 0.05 | — |
| | ap (mm) | 1 | — |
| | ae (mm) | — | — |
| | Coolant | Wet (Internal Coolant Supply) | — |
| | Results | Usable with milling chucks and hydro chucks | |

| Aluminum Alloy ADC12 Case | | Sumitomo | Comp's |
|--|------------------|---|----------------------------------|
| Vertical Machining Center HSK63A  | Tool | ANXS16063RS12 | PCD Cutter |
| | Grade | DA1000 | — |
| | Blade Type | G | — |
| | Cutter Dia. (mm) | 63 | 63 |
| | Number of Teeth | 12 | 8 |
| | vc (m/min) | 1,979 | 1,979 |
| | vf (mm/min) | 10,000 | 8,000 |
| | fz (mm/t) | 0.083 | 0.1 |
| | ap (mm) | 2 | 2 |
| | ae (mm) | — | — |
| | Coolant | Wet (Internal Coolant Supply) | Wet (Internal Coolant Supply) |
| | Results | Machining efficiency increased 1.25x with increased number of teeth Tool life extended 3.6x with reduced load per feed | |

| Aluminum Alloy ADC12 Case | | Sumitomo | Comp's |
|---|------------------|--|----------------------------------|
| Vertical Machining Center BT30  | Tool | ANXA16080R14 | PCD Cutter |
| | Grade | DA1000 | — |
| | Blade Type | L | — |
| | Cutter Dia. (mm) | 80 | 80 |
| | Number of Teeth | 14 | 8 |
| | vc (m/min) | 2,513 | 2,513 |
| | vf (mm/min) | 2,500 | 2,500 |
| | fz (mm/t) | 0.018 | 0.031 |
| | ap (mm) | Roughing 2.0/Finishing 0.2 | Roughing 2.0/Finishing 0.2 |
| | ae (mm) | — | — |
| | Coolant | Wet (Internal Coolant Supply) | Wet (Internal Coolant Supply) |
| | Results | Improved flatness, burrs reduced Drastically reduced runout adjustment time | |

| Aluminum Alloy ADC12 Automotive Component | | Sumitomo | Comp's |
|---|------------------|--|----------------------------------|
| Vertical Machining Center BT30  | Tool | ANXA16125R22 | PCD Cutter |
| | Grade | DA1000 | — |
| | Blade Type | H | — |
| | Cutter Dia. (mm) | 125 | 125 |
| | Number of Teeth | 22 | 6 |
| | vc (m/min) | 3,142 | 3,142 |
| | vf (mm/min) | 14,080 | 3,520 |
| | fz (mm/t) | 0.08 | 0.073 |
| | ap (mm) | 0.8 | 0.8 |
| | ae (mm) | — | — |
| | Coolant | Wet (Internal Coolant Supply) | Wet (External Coolant Supply) |
| | Results | Machining efficiency improved 4x, tool life extended 11x, non-cutting time reduced with lighter body | |

| Aluminum Alloy ADC12 Automotive Component | | Sumitomo | Comp's |
|--|------------------|--|----------------------------------|
| Vertical Machining Center BT30  | Tool | ANXA16125R22 | Carbide Cutter |
| | Grade | DA1000 | Carbide |
| | Blade Type | G | — |
| | Cutter Dia. (mm) | 125 | 125 |
| | Number of Teeth | 22 | 6 |
| | vc (m/min) | 3,534 | 1,000 |
| | vf (mm/min) | Roughing 5,000/Finishing 10,000 | 1,200 |
| | fz (mm/t) | Roughing 0.025/Finishing 0.05 | 0.08 |
| | ap (mm) | Roughing 3.0/Finishing 0.5 | Roughing 3.0/Finishing 0.5 |
| | ae (mm) | — | — |
| | Coolant | Wet (External Coolant Supply) | Wet (External Coolant Supply) |
| | Results | Machining efficiency increased 6x with increased number of teeth Tool life extended 10x | |

| Aluminum Alloy ADC12 Automotive Component | | Sumitomo | Comp's |
|---|------------------|--|----------------------------------|
| Vertical Machining Center BT30  | Tool | ANXS16025E02 | Brazed |
| | Grade | DA1000 | PCD |
| | Blade Type | R0.4 | — |
| | Cutter Dia. (mm) | 25 | 25 |
| | Number of Teeth | 2 | 2 |
| | vc (m/min) | 471 | 471 |
| | vf (mm/min) | 900 | 900 |
| | fz (mm/t) | 0.075 | 0.075 |
| | ap (mm) | 0.3 to 1.5 | 0.3 to 1.5 |
| | ae (mm) | 7 to 10 | 7 to 10 |
| | Coolant | Wet (Internal Coolant Supply) | Wet (External Coolant Supply) |
| | Results | Fine chips with internal coolant supply Economic with indexable blade | |

| CFRP Aerospace Jig | | Sumitomo | — |
|--|------------------|-------------------------------|---|
| Vertical Machining Center BT50  | Tool | ANXS16080R10 | — |
| | Grade | DA1000 | — |
| | Blade Type | G | — |
| | Cutter Dia. (mm) | 80 | — |
| | Number of Teeth | 5 | — |
| | vc (m/min) | 565 | — |
| | vf (mm/min) | 3,000 | — |
| | fz (mm/t) | 0.27 | — |
| | ap (mm) | 1.55 | — |
| | ae (mm) | — | — |
| | Coolant | Dry | — |
| | Results | Good machined surface quality | |

Application Example

| Aluminum Alloy ADC12 Engine Case | | New Product + Current Tool | Current Tool only |
|---|------------------|--|-------------------------------|
| Vertical Machining Center BT40  | Tool | ANXA16100R18 | ANXA16100R18 |
| | Grade | DA1000+SCV10 | DA1000 |
| | Setting | G Type 16 teeth WS Type 2 teeth | G Type 18 teeth |
| | Cutter Dia. (mm) | 100 | 100 |
| | Number of Teeth | 18 | 18 |
| | vc (m/min) | 1,000 | 1,000 |
| | vf (mm/min) | 8,599 | 8,599 |
| | fz (mm/t) | 0.15 | 0.15 |
| | ap (mm) | 0.2 | 0.2 |
| | ae (mm) | — | — |
| | Coolant | Wet (Internal Coolant Supply) | Wet (Internal Coolant Supply) |
| | Results | 6 times or more tool life with burr control Deburring in later processes can be omitted | |

SUMICRYSTAL

| Aluminum Alloy A7075 Electronic Device Housing | | New Product + Current Tool | Current Tool only |
|---|------------------|--|-----------------------------------|
| Vertical Machining Center BT40  | Tool | ANXS16080R06 | ANXS16080R06 |
| | Grade | DA1000+SCV10 | DA1000 |
| | Setting | G Type 4 teeth WS Type 1 tooth Dummy blade 1 tooth | G Type 5 teeth WS Type 1 tooth |
| | Cutter Dia. (mm) | 80 | 80 |
| | Number of Teeth | 5 (+ Dummy Blade 1) | 6 |
| | vc (m/min) | 2,500 | 2,500 |
| | vf (mm/min) | 2,986 | 2,986 |
| | fz (mm/t) | 0.05 | 0.05 |
| | ap (mm) | 0.1 | 0.1 |
| | ae (mm) | — | — |
| | Coolant | Wet (Internal Coolant Supply) | Wet (Internal Coolant Supply) |
| | Results | Achieves Ra0.019 μm (for gloss finishing) | |

SUMICRYSTAL

| Aluminum Alloy ADC12 Automotive Component | | Sumitomo | — |
|---|------------------|---|---|
| Vertical Machining Center BT30  | Tool | ANXA16160RS12 | — |
| | Grade | DA1000 | — |
| | Blade Type | G | — |
| | Cutter Dia. (mm) | 160 | — |
| | Number of Teeth | 12 | — |
| | vc (m/min) | 3,014 | — |
| | vf (mm/min) | 10,000 | — |
| | fz (mm/t) | 0.14 | — |
| | ap (mm) | 0.2 | — |
| | ae (mm) | — | — |
| | Coolant | Wet (Internal Coolant Supply) | — |
| | Results | Good machine surface accuracy Fine chips | |

| ADC12/FC250 Combined milling of engine components | | Sumitomo | Comp's |
|--|------------------|--|-------------------------------|
| Horizontal M/C HSK100  | Tool | ANXA16250R20* | PCD Cutter |
| | Grade | DA90 | — |
| | Blade Type | GB | — |
| | Cutter Dia. (mm) | 250 | 250 |
| | Number of Teeth | 20 | 24 |
| | vc (m/min) | 785 | 785 |
| | vf (mm/min) | 1,000 | 1,200 |
| | fz (mm/t) | 0.05 | 0.05 |
| | ap (mm) | 0.2 | 0.2 |
| | ae (mm) | — | — |
| | Coolant | Wet (Internal Coolant Supply) | Wet (Internal Coolant Supply) |
| | Results | 3x tool life, burrs reduced Good machined surface quality | |

* Made-to-Order Product

| ADC12/PCD450 Combined milling of engine components | | Sumitomo | Conventional Tool |
|--|------------------|---|-------------------------------|
|  | Tool | ANXA16125RS22 | ANXA16125RS22 |
| | Grade | DA90 | DA1000 |
| | Blade Type | GB | H |
| | Cutter Dia. (mm) | 125 | 125 |
| | Number of Teeth | 22 | 22 |
| | vc (m/min) | 353 | 353 |
| | vf (mm/min) | 4,372 | 4,372 |
| | fz (mm/t) | 0.13 | 0.13 |
| | ap (mm) | 0.15 | 0.15 |
| | ae (mm) | — | — |
| | Coolant | Wet (Internal Coolant Supply) | Wet (Internal Coolant Supply) |
| | Results | 1.7x tool life Good machined surface quality | |

| ADC12/PCD450 Combined milling of engine components | | Sumitomo | Conventional Tool |
|--|------------------|--|-------------------------------|
|  | Tool | ANXA16160R28 | PCD Cutter |
| | Grade | ^{New} DA1090 | — |
| | Blade Type | GB | — |
| | Cutter Dia. (mm) | 160 | 160 |
| | Number of Teeth | 28 | 34 |
| | vc (m/min) | 300 | 300 |
| | vf (mm/min) | 2,500 | 3,000 |
| | fz (mm/t) | 0.15 | 0.15 |
| | ap (mm) | 0.2 | 0.2 |
| | ae (mm) | — | — |
| | Coolant | Wet (Internal Coolant Supply) | Wet (Internal Coolant Supply) |
| | Results | 5 times the tool life, burr control Excellent machining quality | |

< SAFETY NOTES >



- Very hot or lengthy chips may be discharged while the machine is in operation. Therefore, machine guards, safety goggles or other protective covers must be used. Fire safety precautions must also be considered.

- Please handle with care as this product has sharp edges.
- Improper cutting conditions or mis-handling of the tool may result in breakages or projectiles. Therefore, please use the tool within its recommended conditions.

- When using non-water soluble cutting oil, precautions against fire must be taken and please ensure that a fire extinguisher is placed near the machine.

 Sumitomo Electric Industries, Ltd.

Hardmetal Division

Global Marketing Department : 1-1-1, Koyakita, Itami, Hyogo 664-0016, Japan

<https://www.sumitool.com/global>