

Threading Tools

F107 to F129



Threading Tools	For External Threading/Internal Threading	SEC-Threading Tool series Selection Guide ... F108
	For External Threading	Basics of Screw Threads F111
		SSTE type / SSTI type F112
	For Internal Threading	SSTE/SSTI type Guidelines for Depth of Cut and No. of Passes ... F118
		STH series (Small Pitch) F120
		GME-TH series (Large Pitch) F121
		LTE series (General-purpose) F122
		STE series (General-purpose) F123
		THE series (General-purpose) / THE series (For Small Lathes) ... F124
		STI series (General-purpose) F125
		STHI series (Small Diameter / General-purpose) F126
		THI series (General-purpose) F127
		Threading Tool Guidelines for Depth of Cut and No. of Passes ... F128

Stock Markings and Symbols

- mark: Standard stocked item
- mark: To be replaced with the new item featured on the same page
- ▲ mark: To be replaced by a new product, made to order, or discontinued (please confirm stock availability)
- * mark: Semi-standard stock (please confirm stock availability)
- mark: Stock or planned stock (please confirm stock availability)
- Blank: Made-to-order item
- mark: Not available

Selection Guide

External Threading

Application Thread Ridge Shape	General Industrial Use				Pipe Coupling for Gas, Water and Water Faucets	Pipe Threads for Steam, Gas and Water Supply Pipes	For Aerospace Equipment		
	Internal Thread 60° Pitch	Internal Thread 55° Pitch	Internal Thread 60° Pitch	Internal Thread 60° Pitch	Internal Thread 55° Pitch	Internal Thread 60° 1°47' Pitch	Internal Thread 55° 1°47' Pitch	Internal Thread 60° 1°47' Pitch	Internal Thread 60° Pitch
Type	60° General-purpose Thread	55° General-purpose Thread (Whitworth)	60° ISO Metric Thread	60° Unified Thread	55° Parallel Thread for Pipe/Whitworth	60° American NPT	55° Taper Thread for Pipe BSPT	60° American NPTF	UNJ 60°
Symbol	M UNC/UNF	W	M	UNC/UNF	G/Rp/W	NPT	R/Rc	NPTF	UNJ
Pitch	mm Threads/Inch	Threads/Inch	mm	Threads/Inch	Threads/Inch	Threads/Inch	Threads/Inch	Threads/Inch	Threads/Inch
Wiper Edge	No	No	Yes	Yes	Yes	Yes	Yes	Yes	Yes
 SSTE type → F112	0.50 to 3.00 48 to 8	48 to 8	0.75, 1.00 1.25, 1.50 1.75, 2.00 2.50, 3.00	32, 28, 24 20, 18, 16 14, 13, 12 10, 8	36, 32, 28 24, 20, 19 18, 16, 14 12, 11, 10 8	27, 18, 14 11.5, 8	28, 19, 14 11	27, 18, 14 11.5	32, 28, 24 20, 18, 16 14, 12, 10
 LTE series → F122	1.00 to 3.00 24 to 8	24 to 10	1.00, 1.25 1.50, 1.75 2.00, 2.50 3.00, 3.50 4.00	24, 20, 18 16, 14, 12 8	—	—	28, 19, 14 11	—	—
 STE type → F123	1.00 to 3.00 24 to 8	24 to 10	1.00, 1.25 1.50, 1.75 2.00, 2.50 3.00	24, 20, 18 16, 14, 12 8	—	—	28, 19, 14 11	—	—
 THE series → F124	0.80 to 3.00	24 to 10	0.80, 1.00 1.25, 1.50 1.75, 2.00 2.50	—	—	—	28, 19	—	—
 GME-TH series → F121	3.00 to 6.00	11 to 4.5	—	—	—	—	—	—	—
 GWC series TTE type Insert → F7	0.20 to 3.00	80 to 8	—	—	—	—	—	—	—
 STH series → F120	0.20 to 1.50	48 to 16	—	—	—	—	—	—	—

Threading Tools

T

Grooving

Cut-off

Threading

External Turning

Facing





Internal Turning

Necking

CBN

Selection Guide

Internal Threading

Application Thread Ridge Shape	General Industrial Use				Pipe Coupling for Gas, Water and Water Faucets	Pipe Threads for Steam, Gas and Water Supply Pipes	For Aerospace Equipment		
	Internal Thread External Thread	Internal Thread External Thread	Internal Thread External Thread	Internal Thread External Thread	Internal Thread External Thread	Internal Thread External Thread	Internal Thread External Thread	Internal Thread External Thread	Internal Thread External Thread
Type	60° General-purpose Thread	55° General-purpose Thread (Whitworth)	60° ISO Metric Thread	60° Unified Thread	55° Parallel Thread for Pipe/Whitworth	60° American NPT	55° Taper Thread for Pipe BSPT	60° American NPTF	UNJ 60°
Symbol	M UNC/UNF	W	M	UNC/UNF	G/Rp/W	NPT	R/Rc	NPTF	UNJ
Pitch	mm Threads/Inch	Threads/Inch	mm	Threads/Inch	Threads/Inch	Threads/Inch	Threads/Inch	Threads/Inch	Threads/Inch
Wiper Edge	No	No	Yes	Yes	Yes	Yes	Yes	Yes	Yes
 SSTI type → F112	0.50 to 3.00 48 to 8	48 to 8	0.75, 1.00 1.25, 1.50 1.75, 2.00 2.50, 3.00	32, 28, 24 20, 18, 16 14, 13, 12 10, 8	28, 24, 20 19	27, 18, 14 11.5, 8	28, 19	27, 18, 14 11.5, 8	32, 28, 24 20, 18, 16 14, 12, 10
 STI type → F125	1.00 to 3.00 24 to 8	—	1.00, 1.25 1.50, 1.75 2.00, 2.50 3.00	—	—	—	—	—	—
 STHI type → F126	0.40 to 1.00	—	—	—	—	—	—	—	—
 SSH series SSHT type Inserts → F63	0.50 to 2.50	—	—	—	—	—	—	—	—
 THI type → F127	0.80 to 2.50	—	1.50, 2.00	—	—	—	—	—	—

Threading
Tools

TL

Grooving

Cut-off

Threading

External
Turning

Facing







Internal
Turning

Necking

CBN

Selection Guide

External Threading Tools

Series	Appearance	Structure						Features	Applicable Thread Symbol	
		Screw-on	Clamp-on	Lever Lock	Drawing Pin	Double Clamp	M		W	
SSTE type	 → F112	●					<ul style="list-style-type: none"> Adopts a flat-mounted 3-cornered insert. Ground cutting edge flank produces superior machined surface with sharp cutting edge. Stable chip control through use of a 3D molded chipbreaker. Large lineup of inserts with a wiper edge. 	M	W	
LTE series STE type	 → F122, F123	●		●			<ul style="list-style-type: none"> LTE series: Lever lock holders 20 / 25 / 32mm square, STE type: Screw-on specifications 12 / 16mm square M-Class flat-mounted 3-cornered insert is economical Range of cermet grades Stable chip control with incorporated chipbreaker 	M	W	
THE series	 → F124	●			●		<ul style="list-style-type: none"> 3-cornered tangentially-mounted G-class insert with excellent sharpness 20 and 25mm square shanks use a strong draw-pin system, while 12 and 16mm square shanks use a screw-on type system. Cermet grades are available for inserts without a wiper edge 	M	W	
GME-TH series	 → F121		●				<ul style="list-style-type: none"> 2-cornered insert adopted for large-pitch threading of 3 to 6mm 55° apex angle available in 11 to 4.5 TPI Strong clamping through the use of clamp plate 	M	W	
GWC series TTE type Insert	 → F7	●			●		<ul style="list-style-type: none"> GWC series lineup includes TTE type inserts for threading 20 and 25mm square shanks use a high-rigidity double clamp system, while 10, 12, and 16mm square shanks use a screw-on type system. Utilises economical 3-cornered inserts 	M	W	
STH series	 → F120	●					<ul style="list-style-type: none"> For small lathes 20mm square or less 2-cornered tangentially-mounted insert enables space-saving threading Can also be used for back-turn threading with bar feeder Can also be used for small-pitch (min. 0.2mm) threading 	M	W	

Internal Threading Tools

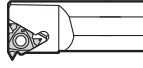
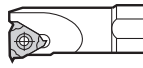
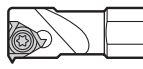
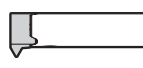
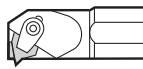
Series	Appearance	Structure						Features	Min. Bore Dia. (mm)	Applicable Thread Symbol	
		Screw-on	Clamp-on	Lever Lock	Drawing Pin	Double Clamp	M			W	
SSTI type	 → F112	●					<ul style="list-style-type: none"> Adopts a flat-mounted 3-cornered insert. Ground cutting edge flank produces superior machined surface with sharp cutting edge. Stable chip control through use of a 3D molded chipbreaker. Large lineup of inserts with a wiper edge. 	ø18	M	W	
STI series	 → F125	●					<ul style="list-style-type: none"> M-Class flat-mounted 3-cornered insert is economical Stable chip control with incorporated chipbreaker Range of cermet grades 	ø20	M	W	
STHI series	 → F126	●					<ul style="list-style-type: none"> Applicable for internal diameters from ø8mm, small pitch (0.4 - 1.0mm) threading Perfect for small product machining 	ø8	M	W	
SSH series SSHT type Insert with Internal Coolant Supply	 → F63	●					<ul style="list-style-type: none"> SSH series lineup includes SSHT type inserts for threading Tough carbide body for stable machining even with small diameters, suppressing chatter Internal coolant supply for outstanding chip control Applicable for internal diameters from ø8mm, small pitch (0.5 - 2.5mm) threading 	ø8	M	W	
THI series	 → F127		●				<ul style="list-style-type: none"> G-Class 3-cornered insert with good sharpness 	ø18	M	W	

Note: The minimum bore diameter is the diameter of the prepared hole.

M : 60° ISO General-purpose Metric Thread
 W : 55° General-purpose Thread (Whitworth)
 UNC/UNF : 60° Unified Thread
 G/Rp/W : 55° Parallel Thread for Pipe
NPT : 60° American NPT
 R/Rc : 55° Taper Thread for Pipe BSPT
 NPTF : 60° American NPTF
 UNJ : 60° UNJ

Threading Tools

F

Grooving

Cut-off

Threading

External Turning

Facing

Internal Turning

Necking

CBN

Basics of Screw Threads

Parts of a Screw Thread

External Thread and **Internal Thread** diagrams show: Thread Root, Thread Ridge, Included Angle, Pitch (P), Minor Diameter (d_m), Pitch Diameter (d_p), and Major Diameter (d).

Lead Angle diagram shows: Conical helix, Lead Angle (α°), Length of one turn, Diameter (d), and Lead (l).

Lead Angle Calculation

$$\tan \alpha^\circ = \frac{l}{\pi \times d} = \frac{n \times P}{\pi \times d}$$

Effective Diameter (d): Diameter of imaginary cylinder that passes through the thread at the point where the groove and ridge widths are equal
 Pitch (P): Distance between two ridges adjacent to each other
 Lead (l): Distance the screw thread moves axially in one turn (On a single threaded screw, the lead and pitch are identical.)
 Lead Angle (α): Angle made by the conical helix of the thread ridge at a pitch diameter with a plane perpendicular to the axis

Main Screw Thread Types and Standard Thread Patterns

Application	Symbol	Basic Profile	Application	Symbol	Basic Profile	Application	Symbol	Basic Profile	Application	Symbol	Basic Profile
Metric Thread	M	Internal Thread: 60°, 1/4P External Thread: 60°, 1/8P	Parallel Thread for Pipe	G(PF) Rp(PS) G(PF)	Internal Thread: 55°, R0.137P External Thread: 55°, R0.137P	Taper Thread for Pipe	Rc(PT) (BSPT) R(PT) (BSPT)	Internal Thread: 27.5°, 27.5°, R0.137P External Thread: 27.5°, 27.5°, R0.137P, 1°47', 90°	Unified Thread	UN UNC UNF UNEF	Internal Thread: 60°, 1/4P External Thread: 60°, 1/8P
Whitworth Thread	W BSW BSP	Internal Thread: 55°, R0.137P External Thread: 55°, R0.137P	Thread for Aerospace Instruments	UNJ	Internal Thread: 60°, 5/16P External Thread: 60°, 5/16P	American Taper Thread for Pipe	NPT	Internal Thread: 30°, 30°, R0.137P External Thread: 30°, 30°, R0.137P, 1°47', 90°	American Taper Thread for Pipe	NPTF	Internal Thread: 30°, 30° External Thread: 30°, 30°, 1°47', 90°

Tool Holder and Insert Selection Guide (SSTE type / SSTI type)

	External Threads (Normal Spindle Rotation)	Internal Threads (Normal Spindle Rotation)	External Threads (Reverse Spindle Rotation)
Right-handed Threading	<p>External Holder (SSTE type) External Diameter Insert (16ER type) Shim (YE3-3P/YE3-2P / YE3-1P/YE3/YE3-1N)</p>	<p>Internal Holder (SSTI type) Internal Insert (16IR type) Shim (Y13-3P/Y13-2P / Y13-1P/Y13/Y13-1N)</p>	<p>External Holder (SSTE type) External Diameter Insert (16ER type) Shim (YE3-3P/YE3-2P / YE3-1P/YE3/YE3-1N)</p>
Left-handed Threading	<p>External Holder (SSTE type) External Diameter Insert (16ER type) Shim (YE3-2N/YE3-3N)</p>	<p>Internal Holder (SSTI type) Internal Insert (16IR type) Shim (Y13-2N/Y13-3N)</p>	<p>External Holder (SSTE type) External Diameter Insert (16ER type) Shim (YE3-2N/YE3-3N)</p>

Threading Method and Insert Angle

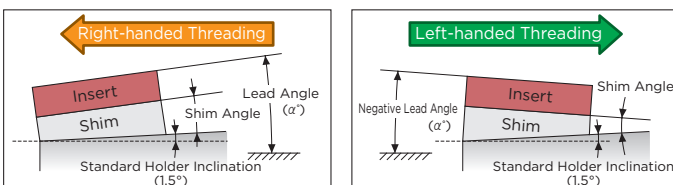

SSTE type/SSTI type

VIDEO OF CUTTING



Threading Tools



Grooving

Cut-off

Threading

External Turning

Facing

Internal Turning

Necking

CBN



Features

- High-precision inserts with wiper edge for threading, supporting a wide range of applications from general industrial machinery to pipes and aerospace devices
- Stable chip control through use of a 3D molded chipbreaker.
- Ground cutting edge flank for improved cutting edge sharpness, resulting in high quality threads

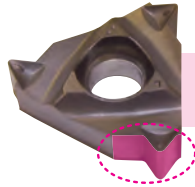

Ground flanks around cutting edge

Product Range

Applications	Type	Wiper Edge	External/Internal	Pitch		Insert Cat. No. Example:
				Pitch (mm)	TPI (Threads/Inch)	
General Industrial Use	60° General-purpose Thread	No	External	0.5 - 3.0	48 to 8	16ER A60-CB
			Internal	0.5 - 3.0	48 to 8	16IR A60-CB
	External		0.5 - 3.0	48 to 8	16ER A55-CB	
	Internal		0.5 - 3.0	48 to 8	16IR A55-CB	
	60° ISO Metric Thread	Yes	External	0.75 - 3.0		16ER 075ISO-CB
			Internal	0.75 - 3.0		16IR 075ISO-CB
	External				16ER 32UN-CB	
	Internal				16IR 32UN-CB	
Pipe Coupling for Gas, Water and Water Faucets	55° Parallel Thread for Pipe/Whitworth		External			16ER 36W-CB
	60° American NPT		External			16ER 27NPT-CB
Steam, Gas and Water Supply Pipes	55° Taper Thread for Pipe BSPT		External			16ER 28BSPT-CB
	60° American NPTF		External			16ER 27NPTF-CB
For Aerospace Equipment	UNJ 60°		External			16ER 32UNJ-CB
			Internal			16IR 32UNJ-CB

Application Examples

Comparison of Cutting Force

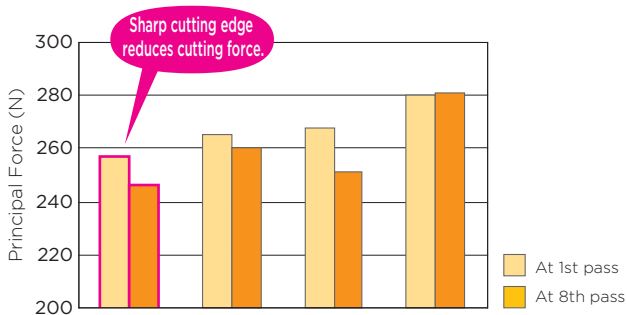

Work Material: S45C M30 x 1.5
Cutting Conditions: vc = 150m/min Wet, 8 Passes Thread Infeed Method: Radial Infeed

Machined Surface Comparison

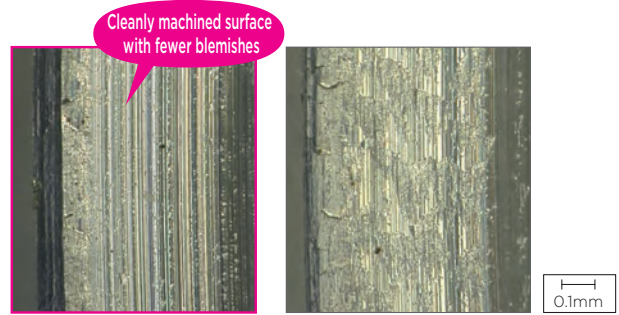

Work Material: S45C M30 x 1.5
Cutting Conditions: vc = 150m/min Wet, 8 Passes Thread Infeed Method: Radial Infeed

SSTE type/SSTI type

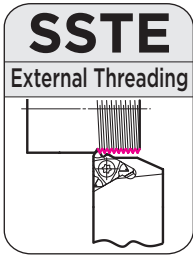
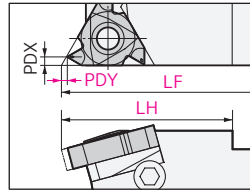
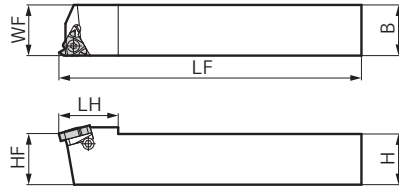

Fig 1



External Turning
Screw-on

The values for dimensions LF and LH below are only for reference. The actual value is the value below minus the PDY value for the corresponding insert on page F114.

Holder

Cat. No.	Stock	Height H	Width B	Overall Length LF	Head LH	Cutting Edge Distance WF	Cutting Edge Height HF
SSTE R1616H16	●	16	16	100	20.5	16	16
R2020K16	●	20	20	125	30.0	20	20
R2525M16	●	25	25	150	30.0	25	25

Parts

Dimensions (mm)

Fig	Flat Head Screw	Shim Screw	Flat Washer	Shim	Wrench
1					
1	BFTX0312N	2.0	BX0304*1	PW3	YE3
1					TRX10

*1: Shim screw wrench is sold separately.

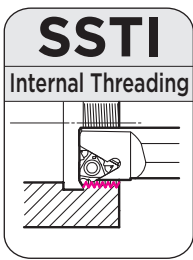

Fig 1

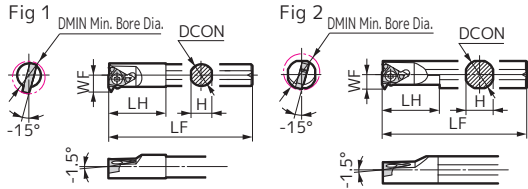

Fig 2

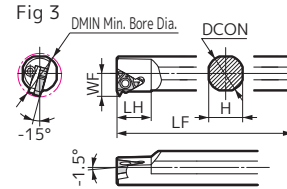
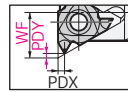
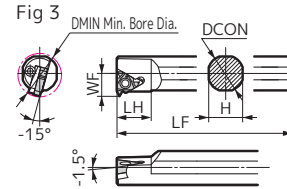

Fig 3



The values for dimension WF below are only for reference. The actual value is the value below minus the PDY value for the corresponding insert on F115.

Internal Threading
Screw-on

Holder

Cat. No.	Stock	Diameter DCON	Height H	Overall Length LF	Head LH	Cutting Edge Distance WF	Min. Bore Dia. DMIN*2
SSTI R1812M16 ^{*3}	●	12	11.0	150	32.0	10.2	18
R2016M16 ^{*3}	●	16	15.0	150	63.5	9.2	20
SSTI R2420Q16	●	20	18.0	180	19.0	13.5	24
R3125S16	●	25	23.0	250	14.3	16.5	31
R3732S16	●	32	30.0	250	14.3	20.0	37

Parts

Dimensions (mm)

Fig	Flat Head Screw	Shim Screw	Flat Washer	Shim	Wrench
1					
1	BFTX03085N	2.0	—	—	—
2					
3	BFTX0312N	2.0	BX0304*1	PW3	YI3
3					TRX10

*1 Shim screw wrench is sold separately. *2 The minimum bore diameter is the diameter of the prepared hole. *3 Left-hand threads are not available.

Shim and Selection Criteria

Application	Recommended Lead Angle (β ₁)	External Threading		Internal Threading	
		Cat. No.	Stock	Cat. No.	Stock
Right-hand Thread	4.5°	YE3-3P	●	YI3-3P	●
	3.5°	YE3-2P	●	YI3-2P	●
	2.5°	YE3-1P	●	YI3-1P	●
	1.5°	YE3 ^{*4}	●	YI3 ^{*4}	●
	0.5°	YE3-1N	●	YI3-1N	●
Left-hand Thread	-0.5°	YE3-2N	●	YI3-2N	●
	-1.5°	YE3-3N	●	YI3-3N	●

*4 Standard shim supplied with holder.

β ₁ = 4.5°	For External: YE3-3P For Internal: YI3-3P	β ₁ = 3.5°	For External: YE3-2P For Internal: YI3-2P	β ₁ = 2.5°	For External: YE3-1P For Internal: YI3-1P
-----------------------	--	-----------------------	--	-----------------------	--

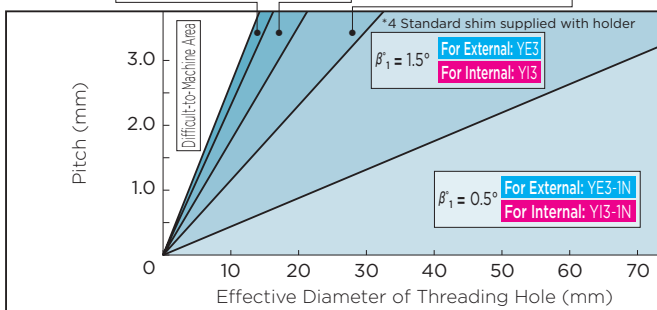

Holder Identification Code

Example: **S S T E R 25 25 M 16**

(1) Series Code SST series	(2) External/Internal Symbol: E External, I Internal	(3) Feed Direction Symbol: R Right-handed	(4) Shank Height/Work Dia. Symbol (mm): External Turning (Shank Height): 16 16, 20 20, 25 25 Internal Threading (Min. Bore Diameter): 18 18, 20 20, 24 24, 31 31, 37 37	(5) Shank Width/ Diameter Symbol (mm): External Turning (Shank Width): 16 16, 20 20, 25 25 Internal Threading (Shank Diameter): 12 12, 16 16, 20 20, 25 25, 32 32	(6) Overall Length Symbol Symbol (mm): H 100, K 125, M 150, Q 180, S 250	(7) Insert Size Symbol: 16 Isosized Circle (mm): 9.525
--------------------------------------	---	---	--	--	---	--



SSTE type/SSTI type

SSTE type Guidelines for Depth of Cut and No. of Passes **F118**



Fig 1

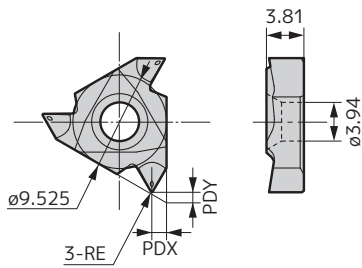
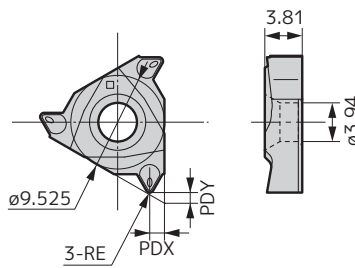

Fig 2



 Coated Carbide

Threading Tools

T

Grooving

Cut-off

60°/55° General-purpose Threads (Without Wiper Edge) Dimensions (mm)

Included Angle	Cat. No.	AC530U	Pitch		X Direction	Y Direction	Corner Radius RE	Pcs/Pack	Fig
			mm	Threads/inch					
60°	16ER A60-CB	●	0.5-1.5	16-48	0.8	0.6	0.09	5	1
	16ER AG60-CB	●	0.5-3.0	8-48	1.5	1.1	0.10		
	16ER G60-CB	●	2.0-3.0	8-14	1.5	1.1	0.20		
55°	16ER A55-CB	●	—	16-48	0.8	0.5	0.05	5	1
	16ER AG55-CB	●	—	8-48	1.5	1.1	0.08		
	16ER G55-CB	●	—	8-14	1.5	1.1	0.22		

60° American NPT (With Wiper Edge) Dimensions (mm)

Included Angle	Cat. No.	AC530U	Pitch		X Direction	Y Direction	Corner Radius RE	Pcs/Pack	Fig
			mm	Threads/inch					
60°	16ER 27NPT-CB	●	—	27	0.8	0.6	0.06	5	2
	16ER 18NPT-CB	●	—	18	0.8	0.6	0.06		
	16ER 14NPT-CB	●	—	14	1.5	1.0	0.08		
	16ER 115NPT-CB	●	—	11.5	1.5	1.0	0.08		
	16ER 08NPT-CB	●	—	8	1.5	1.1	0.13		

Threading

External Turning

60° ISO Metric Thread (With Wiper Edge) Dimensions (mm)

Included Angle	Cat. No.	AC530U	Pitch		X Direction	Y Direction	Corner Radius RE	Pcs/Pack	Fig
			mm	Threads/inch					
60°	16ER 075 ISO-CB	●	0.75	—	0.5	1.0	0.09	5	2
	16ER 100 ISO-CB	●	1.00	—	0.8	0.6	0.14		
	16ER 125 ISO-CB	●	1.25	—	0.8	0.7	0.15		
	16ER 150 ISO-CB	●	1.50	—	0.8	0.7	0.20		
	16ER 175 ISO-CB	●	1.75	—	1.5	1.0	0.23		
	16ER 200 ISO-CB	●	2.00	—	1.5	1.1	0.26		
	16ER 250 ISO-CB	●	2.50	—	1.5	1.2	0.33		
	16ER 300 ISO-CB	●	3.00	—	1.5	1.1	0.41		

55° Taper Thread for Pipe/BSPT (With Wiper Edge) Dimensions (mm)

Included Angle	Cat. No.	AC530U	Pitch		X Direction	Y Direction	Corner Radius RE	Pcs/Pack	Fig
			mm	Threads/inch					
55°	16ER 28BSPT-CB	●	—	28	0.8	0.6	0.13	5	2
	16ER 19BSPT-CB	●	—	19	0.8	0.6	0.18		
	16ER 14BSPT-CB	●	—	14	1.5	1.3	0.25		
	16ER 11BSPT-CB	●	—	11	1.5	1.0	0.31		

Facing

Internal Turning

60° Unified Thread (With Wiper Edge) Dimensions (mm)

Included Angle	Cat. No.	AC530U	Pitch		X Direction	Y Direction	Corner Radius RE	Pcs/Pack	Fig
			mm	Threads/inch					
60°	16ER 32UN-CB	●	—	32	0.5	1.0	0.10	5	2
	16ER 28UN-CB	●	—	28	0.8	0.7	0.11		
	16ER 24UN-CB	●	—	24	0.8	0.7	0.13		
	16ER 20UN-CB	●	—	20	0.8	0.7	0.16		
	16ER 18UN-CB	●	—	18	0.8	0.7	0.18		
	16ER 16UN-CB	●	—	16	0.8	0.8	0.20		
	16ER 14UN-CB	●	—	14	1.5	1.2	0.23		
	16ER 13UN-CB	●	—	13	1.5	1.1	0.26		
	16ER 12UN-CB	●	—	12	1.5	1.0	0.27		
	16ER 10UN-CB	●	—	10	1.5	1.2	0.33		
	16ER 08UN-CB	●	—	8	1.5	1.2	0.42		

60° American NPTF (With Wiper Edge) Dimensions (mm)

Included Angle	Cat. No.	AC530U	Pitch		X Direction	Y Direction	Corner Radius RE	Pcs/Pack	Fig
			mm	Threads/inch					
60°	16ER 27NPTF-CB	●	—	27	0.8	0.6	0.06	5	2
	16ER 18NPTF-CB	●	—	18	0.8	0.6	0.06		
	16ER 14NPTF-CB	●	—	14	1.5	1.0	0.13		
	16ER 115NPTF-CB	●	—	11.5	1.5	1.0	0.12		

Necking

CBN

55° Parallel Thread for Pipe/Whitworth (With Wiper Edge) Dimensions (mm)

Included Angle	Cat. No.	AC530U	Pitch		X Direction	Y Direction	Corner Radius RE	Pcs/Pack	Fig
			mm	Threads/inch					
55°	16ER 36W-CB	●	—	36	0.5	1.0	0.10	5	2
	16ER 32W-CB	●	—	32	0.5	1.0	0.11		
	16ER 28W-CB	●	—	28	0.8	0.6	0.12		
	16ER 24W-CB	●	—	24	0.8	0.6	0.15		
	16ER 20W-CB	●	—	20	0.8	0.6	0.18		
	16ER 19W-CB	●	—	19	0.8	0.6	0.18		
	16ER 18W-CB	●	—	18	0.8	0.6	0.19		
	16ER 16W-CB	●	—	16	0.8	0.6	0.22		
	16ER 14W-CB	●	—	14	1.5	1.0	0.25		
	16ER 12W-CB	●	—	12	1.5	1.1	0.29		
	16ER 11W-CB	●	—	11	1.5	1.1	0.32		
	16ER 10W-CB	●	—	10	1.5	1.1	0.35		
	16ER 08W-CB	●	—	8	1.5	1.1	0.43		

60° UNJ (With Wiper Edge) Dimensions (mm)

Included Angle	Cat. No.	AC530U	Pitch		X Direction	Y Direction	Corner Radius RE	Pcs/Pack	Fig
			mm	Threads/inch					
60°	16ER 32UNJ-CB	●	—	32	0.5	1.0	0.13	5	2
	16ER 28UNJ-CB	●	—	28	0.8	0.6	0.15		
	16ER 24UNJ-CB	●	—	24	0.8	0.6	0.18		
	16ER 20UNJ-CB	●	—	20	0.8	0.7	0.21		
	16ER 18UNJ-CB	●	—	18	0.8	0.6	0.23		
	16ER 16UNJ-CB	●	—	16	0.8	0.6	0.25		
	16ER 14UNJ-CB	●	—	14	1.5	1.1	0.29		
	16ER 12UNJ-CB	●	—	12	1.5	1.1	0.34		
	16ER 10UNJ-CB	●	—	10	1.5	1.1	0.40		

Insert Identification Code

Example: **16 E R 150 ISO - CB**

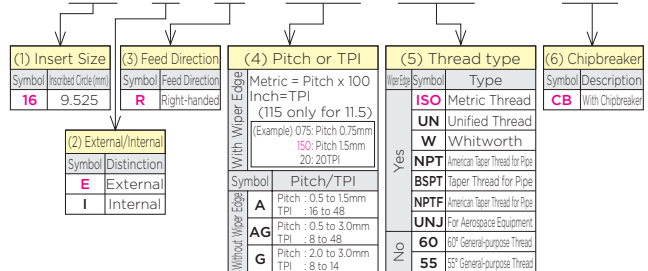

For these inserts, only SSTE type holders can be used.

SSTE type/SSTI type



Fig 1

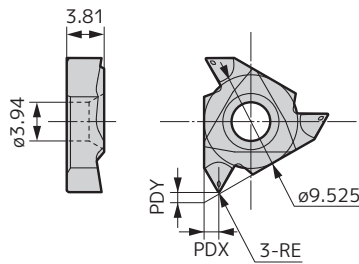
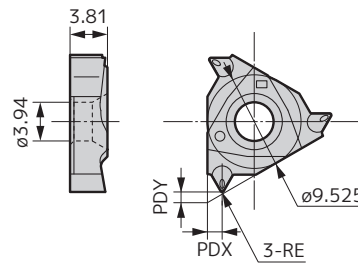

Fig 2



SSTI type Guidelines for Depth of Cut and No. of Passes **F119**

(Coated Carbide)

60°/55° General-purpose Threads (Without Wiper Edge) Dimensions (mm)

Included Angle	Cat. No.	AC530U	Pitch		X Direction	Y Direction	Corner Radius	Pcs/Pack	Fig
			mm	Threads/inch					
60°	161R A60-CB	●	0.5-1.5	16-48	0.8	0.5	0.09	5	1
	161R AG60-CB	●	0.5-3.0	8-48	1.5	1.1	0.10		
	161R G60-CB	●	2.0-3.0	8-14	1.5	1.1	0.18		
55°	161R A55-CB	●	—	16-48	0.8	0.5	0.05	5	1
	161R AG55-CB	●	—	8-48	1.5	1.1	0.08		
	161R G55-CB	●	—	8-14	1.5	1.1	0.20		

60° American NPT (With Wiper Edge) Dimensions (mm)

Included Angle	Cat. No.	AC530U	Pitch		X Direction	Y Direction	Corner Radius	Pcs/Pack	Fig
			mm	Threads/inch					
60°	161R 27NPT-CB	●	—	27	0.8	0.6	0.06	5	2
	161R 18NPT-CB	●	—	18	0.8	0.6	0.06		
	161R 14NPT-CB	●	—	14	1.5	1.1	0.08		
	161R 115NPT-CB	●	—	11.5	1.5	1.0	0.08		
	161R 08NPT-CB	●	—	8	1.5	1.0	0.13		

60° ISO Metric Thread (With Wiper Edge) Dimensions (mm)

Included Angle	Cat. No.	AC530U	Pitch		X Direction	Y Direction	Corner Radius	Pcs/Pack	Fig
			mm	Threads/inch					
60°	161R 075 ISO-CB	●	0.75	—	0.5	0.9	0.04	5	2
	161R 100 ISO-CB	●	1.00	—	0.8	0.6	0.06		
	161R 125 ISO-CB	●	1.25	—	0.8	0.6	0.07		
	161R 150 ISO-CB	●	1.50	—	0.8	0.6	0.09		
	161R 175 ISO-CB	●	1.75	—	1.5	1.0	0.10		
	161R 200 ISO-CB	●	2.00	—	1.5	1.1	0.13		
	161R 250 ISO-CB	●	2.50	—	1.5	1.1	0.15		
	161R 300 ISO-CB	●	3.00	—	1.5	1.1	0.19		

55° Taper Thread for Pipe/BSPT (With Wiper Edge) Dimensions (mm)

Included Angle	Cat. No.	AC530U	Pitch		X Direction	Y Direction	Corner Radius	Pcs/Pack	Fig
			mm	Threads/inch					
55°	161R 28BSPT-CB	●	—	28	0.8	0.6	0.13	5	2
	161R 19BSPT-CB	●	—	19	0.8	0.6	0.18		

60° American NPTF (With Wiper Edge) Dimensions (mm)

Included Angle	Cat. No.	AC530U	Pitch		X Direction	Y Direction	Corner Radius	Pcs/Pack	Fig
			mm	Threads/inch					
60°	161R 27NPTF-CB	●	—	27	0.8	0.6	0.06	5	2
	161R 18NPTF-CB	●	—	18	0.8	0.6	0.08		
	161R 14NPTF-CB	●	—	14	1.5	1.0	0.13		
	161R 115NPTF-CB	●	—	11.5	1.5	1.0	0.08		
	161R 08NPTF-CB	●	—	8	1.5	1.1	0.13		

60° Unified Thread (With Wiper Edge) Dimensions (mm)

Included Angle	Cat. No.	AC530U	Pitch		X Direction	Y Direction	Corner Radius	Pcs/Pack	Fig
			mm	Threads/inch					
60°	161R 32UN-CB	●	—	32	0.5	0.9	0.04	5	2
	161R 28UN-CB	●	—	28	0.8	0.6	0.06		
	161R 24UN-CB	●	—	24	0.8	0.7	0.06		
	161R 20UN-CB	●	—	20	0.8	0.6	0.08		
	161R 18UN-CB	●	—	18	0.8	0.6	0.08		
	161R 16UN-CB	●	—	16	0.8	0.7	0.09		
	161R 14UN-CB	●	—	14	1.5	1.1	0.13		
	161R 13UN-CB	●	—	13	1.5	1.1	0.11		
	161R 12UN-CB	●	—	12	1.5	1.1	0.13		
	161R 10UN-CB	●	—	10	1.5	1.1	0.15		
	161R 08UN-CB	●	—	8	1.5	1.1	0.20		

60° UNJ (With Wiper Edge) Dimensions (mm)

Included Angle	Cat. No.	AC530U	Pitch		X Direction	Y Direction	Corner Radius	Pcs/Pack	Fig
			mm	Threads/inch					
60°	161R 32UNJ-CB	●	—	32	0.5	0.9	0.04	5	2
	161R 28UNJ-CB	●	—	28	0.8	0.6	0.05		
	161R 24UNJ-CB	●	—	24	0.8	0.6	0.06		
	161R 20UNJ-CB	●	—	20	0.8	0.6	0.06		
	161R 18UNJ-CB	●	—	18	0.8	0.6	0.06		
	161R 16UNJ-CB	●	—	16	0.8	0.6	0.09		
	161R 14UNJ-CB	●	—	14	1.5	1.1	0.09		
	161R 12UNJ-CB	●	—	12	1.5	1.1	0.11		
	161R 10UNJ-CB	●	—	10	1.5	1.1	0.15		

55° Parallel Thread for Pipe/Whitworth (With Wiper Edge) Dimensions (mm)

Included Angle	Cat. No.	AC530U	Pitch		X Direction	Y Direction	Corner Radius	Pcs/Pack	Fig
			mm	Threads/inch					
55°	161R 28W-CB	●	—	28	0.8	0.6	0.12	5	2
	161R 24W-CB	●	—	24	0.8	0.6	0.14		
	161R 20W-CB	●	—	20	0.8	0.6	0.18		
	161R 19W-CB	●	—	19	0.8	0.6	0.18		

Insert Identification Code

Example: **16 I R 150 ISO - CB**

(1) Insert Size Symbol: Inscribed Circle (mm) 16	(2) External/Internal Symbol: Distinction I Internal	(3) Feed Direction Symbol: Feed Direction R Right-handed	(4) Pitch or TPI Metric = Pitch x 100 Inch=TPI (115 only for 11.5) (Example) 075: Pitch 0.75mm 150: Pitch 1.5mm 20: 20TPI	(5) Thread type Wiper Edge Symbol Type ISO Metric Thread UN Unified Thread NPT American Taper Thread for Pipe W Whitworth NPT American Taper Thread for Pipe BSPT Taper Thread for Pipe NPTF American Taper Thread for Pipe UNJ For Aerospace Equipment 60 60° General-purpose Thread 55 55° General-purpose Thread	(6) Chipbreaker Symbol: Description CB With Chipbreaker
--	--	--	---	--	---

For these inserts, only SSTI type holders can be used.

Threading Tools

TL

Grooving

Cut-off

Threading

External

Facing

Internal

Necking

CBN

SSTE type/SSTI type

Shim Selection

If the pitch is large or thread diameter is small, the lead angle of the thread becomes larger and the effective relief angle of the leading edge becomes smaller.

It is ideal to set the threading insert so that both right and left relief angles are equal.

Therefore, it is necessary to select an appropriate shim based on the thread pitch and effective diameter using the table below.

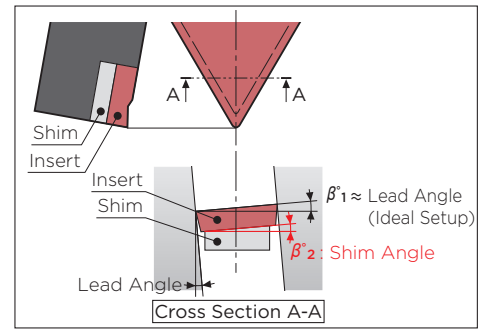

Shim Selection Procedure

- (1) Choose from [Right-Hand Thread / Left-Hand Thread] in the table.
- (2) Locate the required threading "pitch".
- (3) Locate the cell with the required "Effective Diameter" range.
- (4) Confirm the part no. at the "Shim" row above the corresponding "Effective Diameter" cell located previously. If the shim part no. is different from the one currently in use, change to the correct one.

Example: When turning an M16x2.0 external right-hand thread, the pitch diameter is **14.701mm**. In the table below, locate **[2.0]**mm under the "Pitch" column and then move along the row to the right to locate the required "Effective Diameter" range **[11.4 - 17.4]**mm. As such, the correct shim should be **[YE3-1P]**, shown in the corresponding cell under the "External Turning" row below.

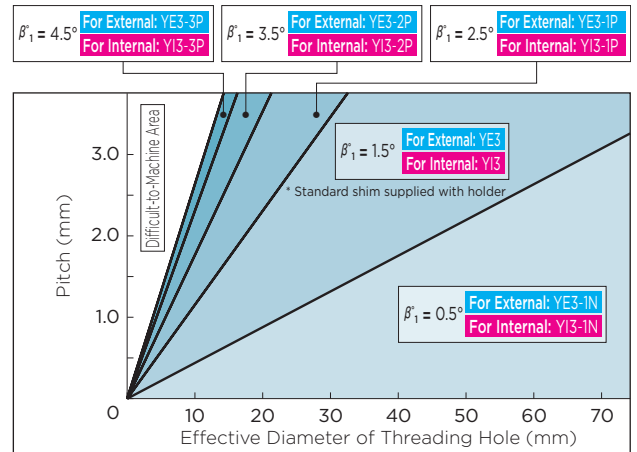

Pitch (mm)

Right-hand/Left-hand Thread	For Right-hand Thread					For Left-hand Thread	
Lead Angle	4.5°	3.5°	2.5°	1.5°	0.5°	-0.5°	-1.5°
Shim	External Threading: YE3-3P Internal Threading: YI3-3P	External Threading: YE3-2P Internal Threading: YI3-2P	External Threading: YE3-1P Internal Threading: YI3-1P	YE3* YI3*	External Threading: YE3-1N Internal Threading: YI3-1N	External Threading: YE3-2N Internal Threading: YI3-2N	External Threading: YE3-3N Internal Threading: YI3-3N
Shim Angle (β_2)	3°	2°	1°	0°	-1°	-2°	-3°
Pitch (mm)	Effective Diameter (mm)						
0.5	1.9 - 2.2	2.2 - 2.8	2.8 - 4.3	4.3 - 11.4	> 11.4	> 11.4	11.4 - 4.3
0.75	2.8 - 3.3	3.3 - 4.3	4.3 - 6.5	6.5 - 17.1	> 17.1	> 17.1	17.1 - 6.5
1.0	3.8 - 4.3	4.3 - 5.7	5.7 - 8.7	8.7 - 22.8	> 22.8	> 22.8	22.8 - 8.7
1.25	4.7 - 5.4	5.4 - 7.1	7.1 - 10.9	10.9 - 28.5	> 28.5	> 28.5	28.5 - 10.9
1.5	5.7 - 6.5	6.5 - 8.5	8.5 - 13.0	13.0 - 34.2	> 34.2	> 34.2	34.2 - 13.0
1.75	6.6 - 7.6	7.6 - 10.0	10.0 - 15.2	15.2 - 39.9	> 39.9	> 39.9	39.9 - 15.2
2.0	7.6 - 8.7	8.7 - 11.4	11.4 - 17.4	17.4 - 45.6	> 45.6	> 45.6	45.6 - 17.4
2.5	9.5 - 10.8	10.8 - 14.2	14.2 - 21.7	21.7 - 57.0	> 57.0	> 57.0	57.0 - 21.7
3.0	11.4 - 13.0	13.0 - 17.1	17.1 - 26.0	26.0 - 68.4	> 68.4	> 68.4	68.4 - 26.0

TPI (threads/inch)

Right-hand/Left-hand Thread	For Right-hand Thread					For Left-hand Thread	
Lead Angle	4.5°	3.5°	2.5°	1.5°	0.5°	-0.5°	-1.5°
Shim	External Threading: YE3-3P Internal Threading: YI3-3P	External Threading: YE3-2P Internal Threading: YI3-2P	External Threading: YE3-1P Internal Threading: YI3-1P	YE3* YI3*	External Threading: YE3-1N Internal Threading: YI3-1N	External Threading: YE3-2N Internal Threading: YI3-2N	External Threading: YE3-3N Internal Threading: YI3-3N
Shim Angle (β_2)	3°	2°	1°	0°	-1°	-2°	-3°
TPI (Threads/Inch)	Effective Diameter (mm)						
32	3.0 - 3.3	3.3 - 4.6	4.6 - 6.9	6.9 - 18.0	> 18.0	> 18.0	18.0 - 6.9
28	3.0 - 3.8	3.8 - 5.1	5.1 - 7.9	7.9 - 20.8	> 20.8	> 20.8	20.8 - 7.9
27	3.6 - 4.1	4.1 - 5.3	5.3 - 8.1	8.1 - 21.3	> 21.3	> 21.3	21.3 - 8.1
24	4.1 - 4.6	4.6 - 6.1	6.1 - 9.1	9.1 - 24.4	> 24.4	> 24.4	24.4 - 9.1
20	4.8 - 5.6	5.6 - 7.1	7.1 - 10.9	10.9 - 29.0	> 29.0	> 29.0	29.0 - 10.9
18	5.3 - 6.1	6.1 - 8.1	8.1 - 12.4	12.4 - 32.5	> 32.5	> 32.5	32.5 - 12.4
16	5.8 - 6.9	6.9 - 8.9	8.9 - 13.7	13.7 - 35.8	> 35.8	> 35.8	35.8 - 13.7
14	6.9 - 7.9	7.9 - 10.2	10.2 - 15.7	15.7 - 41.1	> 41.1	> 41.1	41.1 - 15.7
13	7.4 - 8.4	8.4 - 11.2	11.2 - 17.0	17.0 - 44.7	> 44.7	> 44.7	44.7 - 17.0
12	8.1 - 9.1	9.1 - 12.2	12.2 - 18.5	18.5 - 48.8	> 48.8	> 48.8	48.8 - 18.5
11.5	8.4 - 9.7	9.7 - 12.4	12.4 - 19.3	19.3 - 50.3	> 50.3	> 50.3	50.3 - 19.3
11	8.9 - 9.9	9.9 - 13.2	13.2 - 20.1	20.1 - 52.6	> 52.6	> 52.6	52.6 - 20.1
10	9.7 - 10.9	10.9 - 14.5	14.5 - 22.1	22.1 - 57.9	> 57.9	> 57.9	57.9 - 22.1
9	10.7 - 12.2	12.2 - 16.0	16.0 - 24.4	24.4 - 64.3	> 64.3	> 64.3	64.3 - 24.4
8	11.9 - 13.7	13.7 - 18.0	18.0 - 27.7	27.7 - 72.4	> 72.4	> 72.4	72.4 - 27.7



*SSTE type / SSTI type holders are shipped with shims for a lead angle of $\beta_1 = 1.5^\circ$ (SSTE type: **YE3**, SSTI type: **YI3**).

Shims for lead angles of $\beta_1 = -1.5^\circ, -0.5^\circ, 0.5^\circ, 2.5^\circ, 3.5^\circ$, and 4.5° are sold separately.

*Shims are not needed for SSTI R1812M16 and SSTI R2016M16. (The holders are already provided with the standard holder inclination of 1.5° .)

SSTE type/SSTI type

Shim Replacement

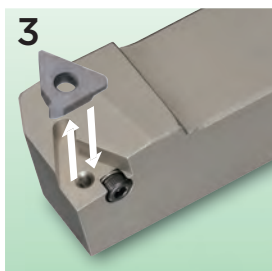
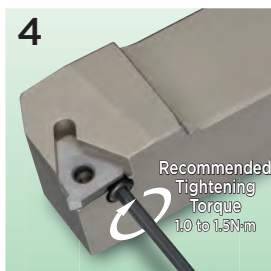
 <p>1</p>	 <p>2</p>	 <p>3</p>	 <p>4</p>
<p>Remove the insert to expose the shim.</p>	<p>Loosen the shim screw by one to two turns.</p>	<p>Remove the shim and attach a different shim that matches the lead.</p>	<p>Tighten the shim screw. (Recommended tightening torque 1.0 to 1.5N·m)</p>

Wiper Edge

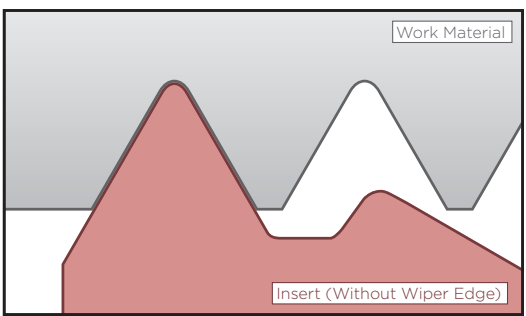
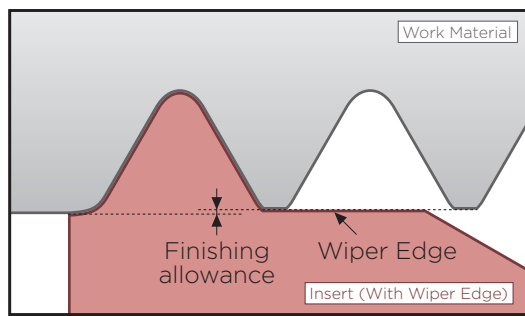
Without Wiper Edge	With Wiper Edge
	
<ul style="list-style-type: none"> · Performs threading without machining thread ridges (the machined surface from the previous process is left unworked.) · Enables machining of threads with different pitch widths with the same insert. · Finishing of the internal (or external) diameter is required before the threading process. · Fine burrs are easily formed on edges of ridges. 	<ul style="list-style-type: none"> · Enables turning of workpieces into shapes compliant with thread standards. · Only specific thread specifications and pitch can be machined. · In order to finish a thread with the wiper edge, a finishing allowance of 0.1mm on each side is required. · Edges of ridges can be rounded off.

Infeed Method

The modified flank infeed is recommended for the SSTE type / SSTI type.

This infeed method, which features reduced chip curl diameters and stable chip control, can also decrease chipping on trailing edges that often occurs in radial infeed machining. (1° is recommended for the modification angle.)

Work Material: SUS316, M30 x 1.5 Cutting Conditions: vc = 60m/min Wet, 8 Passes

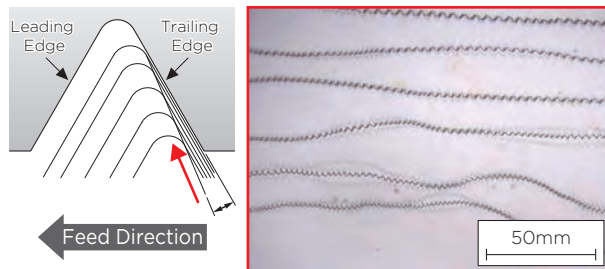
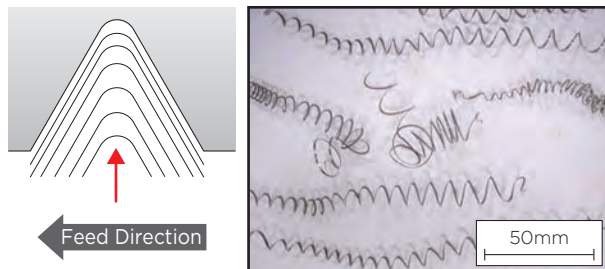
<p>Modified Flank Infeed</p>  <p>Reduced curl diameters ensure smooth, stable chip control (performance).</p>	<p>Radial Infeed Machining</p>  <p>Large curl diameters cause unstable chip control.</p>
---	---

Guide to Depth of Cut and No. of Passes

SSTE type Guidelines for Depth of Cut

External Metric Threads (Depth of cut per pass: mm)

Pitch (mm)	0.75	1.00	1.25	1.50	1.75	2.00	2.50	3.00
Overall Depth of Cut (mm)	0.48	0.64	0.80	0.92	1.10	1.26	1.57	1.87
No. of Passes	4	5	7	8	10	12	14	16
1	0.24	0.25	0.25	0.28	0.28	0.30	0.38	0.40
2	0.12	0.15	0.15	0.15	0.15	0.16	0.19	0.22
3	0.07	0.11	0.12	0.12	0.12	0.13	0.15	0.15
4	0.05	0.08	0.09	0.10	0.10	0.10	0.10	0.13
5		0.05	0.08	0.09	0.10	0.09	0.10	0.12
6			0.06	0.07	0.09	0.09	0.09	0.10
7			0.05	0.06	0.08	0.08	0.09	0.10
8				0.05	0.07	0.07	0.08	0.09
9					0.06	0.07	0.08	0.09
10					0.05	0.06	0.07	0.08
11						0.06	0.07	0.08
12						0.05	0.06	0.07
13							0.06	0.07
14							0.05	0.06
15								0.06
16								0.05

External Unified Threads (Depth of cut per pass: mm)

Threads/Inch	32	28	24	20	18	16	14	13	12	11	10	9	8
Overall Depth of Cut (mm)	0.50	0.57	0.67	0.80	0.89	1.00	1.15	1.23	1.34	1.46	1.60	1.78	2.00
No. of Passes	4	4	5	7	8	10	11	12	12	14	14	16	16
1	0.24	0.25	0.25	0.26	0.26	0.28	0.28	0.30	0.30	0.30	0.38	0.38	0.40
2	0.14	0.17	0.19	0.15	0.15	0.15	0.15	0.18	0.18	0.18	0.20	0.20	0.25
3	0.07	0.10	0.12	0.10	0.12	0.10	0.12	0.13	0.13	0.13	0.15	0.13	0.19
4	0.05	0.05	0.06	0.09	0.10	0.09	0.10	0.10	0.12	0.12	0.12	0.12	0.16
5			0.05	0.08	0.08	0.08	0.10	0.08	0.11	0.11	0.10	0.11	0.14
6				0.07	0.07	0.07	0.09	0.08	0.10	0.10	0.09	0.10	0.12
7				0.05	0.06	0.07	0.08	0.07	0.09	0.08	0.09	0.10	0.11
8					0.05	0.06	0.07	0.07	0.08	0.08	0.08	0.09	0.10
9						0.05	0.06	0.06	0.07	0.07	0.08	0.09	0.09
10						0.05	0.05	0.06	0.06	0.07	0.07	0.08	0.08
11							0.05	0.05	0.05	0.06	0.07	0.08	0.07
12								0.05	0.05	0.06	0.06	0.07	0.07
13										0.05	0.06	0.07	0.06
14										0.05	0.05	0.06	0.06
15												0.05	0.05
16												0.05	0.05

No. of passes and depths of cut in the table above are general guidelines only. Increase or decrease depending on conditions. However, the maximum depth of cut should be kept to 0.5mm or less.

When using an insert with a wiper edge, add machining allowance to the total depth of cut.

Recommended Cutting Conditions

Work Material	P Carbon Steel	P Alloy Steel (up to 330HB)	M Stainless Steel	K Grey Cast Iron (up to 330HB)	K Ductile Cast Iron	S Titanium Alloy
Cutting Speed vc (m/min)	75-150	75-135	60-120	90-180	75-135	24-90

Guide to Depth of Cut and No. of Passes

SSTI type Guidelines for Depth of Cut

Internal Metric Threads (Depth of cut per pass: mm)

Pitch (mm)	0.75	1.00	1.25	1.50	1.75	2.00	2.50	3.00
Overall Depth of Cut (mm)	0.49	0.58	0.74	0.89	1.04	1.18	1.47	1.76
No. of Passes	4	5	8	10	11	12	14	16
1	0.20	0.22	0.22	0.25	0.25	0.25	0.30	0.30
2	0.12	0.14	0.14	0.12	0.17	0.18	0.19	0.20
3	0.12	0.10	0.09	0.08	0.10	0.12	0.15	0.17
4	0.05	0.07	0.07	0.08	0.08	0.10	0.12	0.14
5		0.05	0.06	0.07	0.08	0.09	0.10	0.12
6			0.06	0.07	0.07	0.08	0.09	0.11
7			0.05	0.06	0.07	0.07	0.08	0.10
8			0.05	0.06	0.06	0.07	0.08	0.10
9				0.05	0.06	0.06	0.07	0.08
10				0.05	0.05	0.06	0.07	0.08
11					0.05	0.05	0.06	0.07
12						0.05	0.06	0.07
13							0.05	0.06
14							0.05	0.06
15								0.05
16								0.05

Internal Unified Threads (Depth of cut per pass: mm)

Threads/Inch	32	28	24	20	18	16	14	13	12	11	10	9	8
Overall Depth of Cut (mm)	0.43	0.49	0.57	0.69	0.76	0.86	0.98	1.06	1.15	1.25	1.37	1.53	1.72
No. of Passes	4	4	5	7	8	10	11	12	12	14	14	16	16
1	0.20	0.20	0.20	0.22	0.22	0.22	0.25	0.25	0.27	0.27	0.27	0.30	0.30
2	0.10	0.16	0.16	0.12	0.13	0.13	0.15	0.15	0.16	0.16	0.18	0.18	0.22
3	0.08	0.08	0.09	0.09	0.10	0.08	0.10	0.10	0.12	0.12	0.16	0.16	0.18
4	0.05	0.05	0.07	0.08	0.08	0.08	0.08	0.08	0.10	0.10	0.12	0.11	0.15
5			0.05	0.07	0.07	0.07	0.07	0.08	0.09	0.08	0.10	0.09	0.12
6				0.06	0.06	0.07	0.07	0.07	0.08	0.08	0.09	0.09	0.11
7				0.05	0.05	0.06	0.06	0.07	0.07	0.07	0.08	0.08	0.10
8					0.05	0.06	0.06	0.06	0.06	0.07	0.07	0.08	0.09
9						0.05	0.05	0.06	0.06	0.06	0.06	0.07	0.08
10						0.04	0.05	0.05	0.05	0.06	0.06	0.07	0.07
11							0.04	0.05	0.05	0.05	0.05	0.06	0.06
12								0.04	0.04	0.05	0.05	0.06	0.06
13										0.04	0.04	0.05	0.05
14										0.04	0.04	0.05	0.05
15												0.04	0.04
16												0.04	0.04

No. of passes and depths of cut in the table above are general guidelines only. Increase or decrease depending on conditions. However, the maximum depth of cut should be kept to 0.5mm or less.

When using an insert with a wiper edge, add machining allowance to the total depth of cut.

Recommended Cutting Conditions

Work Material	P Carbon Steel	P Alloy Steel (up to 330HB)	M Stainless Steel	K Grey Cast Iron (up to 330HB)	K Ductile Cast Iron	S Titanium Alloy
Cutting Speed v_c (m/min)	75-150	75-135	60-120	90-180	75-135	24-90

STH series



External Turning
Screw-on

M Metric Thread
W Whitworth Thread



Threading Tools

T

Grooving

Cut-off

Threading

External Turning

Facing

Internal Turning

Necking

CBN

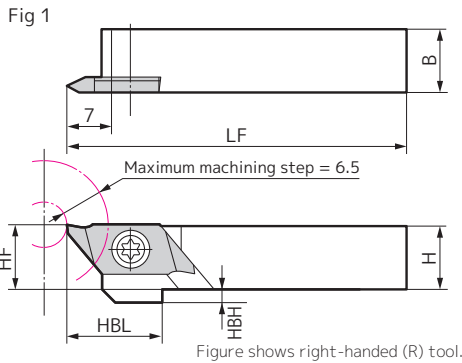
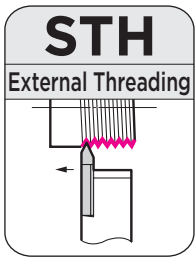

Holder

Parts

Dimensions (mm)

Cat. No.	Stock		Height H	Width B	Overall Length LF	Cutting Edge Height HF	Step HBH	Bottom Offset HBL	Applicable Insert	Fig	Flat Head Screw	Wrench
	R	L										
STH R/L0810	●	●	8	10	120	8	4	15	TH R/L type	1	BFTX0410NTW	RT08
R/L1010	●	●	10	10	120	10	2	15				
R/L1212F	●	●	12	12	85	12	—	15				
R/L1212	●	●	12	12	120	12	—	15				
R/L1616H	●	●	16	16	100	16	—	15				
R/L1616	●	●	16	16	120	16	—	15				
R/L2020	●	●	20	20	80	20	—	15		1		

Insert (Coated Carbide)

Dimensions (mm)

Cat. No.	ACZ150		Pitch		Overall Length L	Height W1	Corner Radius RE	X Direction PDX	Included Angle PNA	Cutting Edge Shape	Applicable Holder	Fig	Figure shows right-handed (R) tool.	
	R	L	mm	Threads/Inch									(A) Flat Shape	(B) Radius
TH R/L6002075A	●	●	0.20 to 0.75	—	20	8	—	0.40	60	(A)	STH series	1		
R/L6002075B	●	●	0.20 to 0.75	—	20	8	—	0.40	60	(B)				
R/L6005125A	●	●	0.50 to 1.25	—	20	8	0.05	0.80	60	(A)				
R/L6005125B	●	●	0.50 to 1.25	—	20	8	0.05	0.80	60	(B)				
R/L601015N	●	●	1.00 to 1.50	—	20	8	0.10	1.25	60	(B)				
R/L550515A	●	●	0.529 to 1.58	48 to 16	20	8	0.05	0.80	55	(B)				
R/L550515B	●	●	0.529 to 1.58	48 to 16	20	8	0.05	0.80	55	(B)				

Holder/Insert Combinations

Recommended Cutting Conditions **A24**

Feed Direction	Right-handed		Left-handed	
	Guide Bush Side	Back Turning Side	Guide Bush Side	Back Turning Side
Cutting Edge Position				
Threading Condition				
Holder	STH R (Right-Hand)	STH R (Right-Hand)	STH L (Left-Hand)	STH L (Left-Hand)
Insert	TH R...A	TH R...B	TH L...B	TH L...A
Features	It is often used in common tooling for workpieces that have a thread at their top end. In this type of tooling, the necking width indicated with the arrow can be reduced, since the cutting edge point is placed closer to the guide bush side.		Often used when a thread is at the middle of the workpiece or at the rear. In this type of tooling, the necking width indicated with the arrow can be reduced, since the cutting edge point is placed closer to the back turning side.	
			With a left hand holder used, a sufficient cutting distance can be kept since the cutting edge position is separate from the guide bush. For the left-hand holder, the selection of A type and B type is the reverse of the right-hand holder. (B indicates the guide bush side while A indicates the back turning side.)	

GME-TH series



Clamp-on
for Large External Pitch

M Metric Thread
W Whitworth Thread

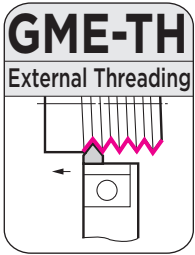

Fig 1

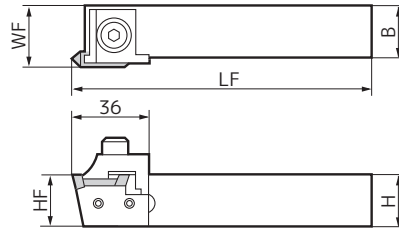

Figure shows right-handed (R) tool.

Holder

Parts

Dimensions (mm)

Cat. No.	Stock		Height H	Width B	Overall Length LF	Cutting Edge Distance WF	Cutting Edge Height HF	Fig	Clamp Plate	Support	Cap Screw	Wrench
	R	L										
GME R/L2525TH			25	25	144.7	29.3	25	1				
R/L2525THL			25	25	150.0	29.3	25	1	GTCR/L	GTR/L	BX0414 (For Support) BX0820 (For Clamp Plate)	LH030 (For Support) LH060 (For Clamp Plate)
R/L3232TH			32	32	170.0	36.3	32	1				

Inserts (□Cemented Carbide)

Dimensions (mm)

Cat. No.	ST20E	A30	G10E	Pitch		Thread Ridge PNA	Corner Radius RE	Fig
				mm	Threads/Inch			
MTG 40		●		3 to 4	—	60	0.3	1
50		●		5	—	60	0.4	1
60		●		6	—	60	0.5	1
MWG 40		●		—	11 to 9.0	55	0.3	1
50		●		—	8 to 6.0	55	0.4	1
60		●		—	5 to 4.5	55	0.6	1

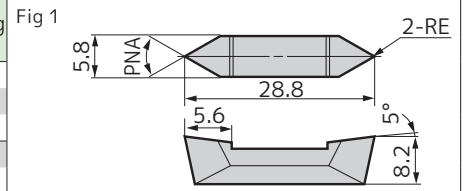

Recommended Cutting Conditions

Work Material	P Carbon Steel	P Alloy Steel	M Stainless Steel
Cutting Speed vc (m/min)	70-120	70-100	70-100

Threading
Tools

T

Grooving

Cut-off

Threading

External
Turning

Facing

Internal
Turning

Necking

CBN

SEC-External Threading Tool Holders LTE series



External Turning
Screw-on / Lever Lock

- M** Metric Thread
- W** Whitworth Thread
- UNC/UNF** Unified Thread
- R/Rc** Taper Thread for Pipe

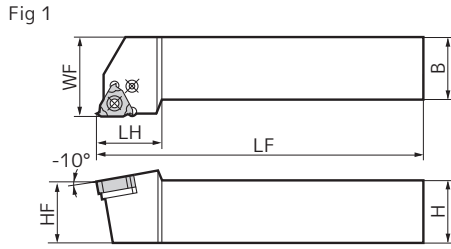
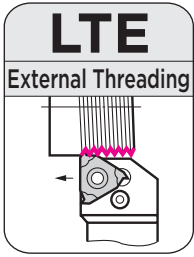

Holder

Parts

Dimensions (mm)

Cat. No.	Stock	Height H	Width B	Overall Length LF	Cutting Edge Distance WF	Cutting Edge Height HF	Head LH	Fig	Parts				
									Lever Pin	Bolt	Shim	Shim Retainer	Wrench
LTE R2020	●	20	20	125	25	20	25	1					
R2525	●	25	25	150	32	25	25	1	LCL3S	LCS3TE	LSTE31-0	LSP3	LH025
LTE R2525M22	●	25	25	150	32	25	28	1					
R3232P22	●	32	32	170	40	32	28	1	LCL4S	LCS4	LSTE42-0	LSP4	LH030

Refer to page F129 for shim selection.

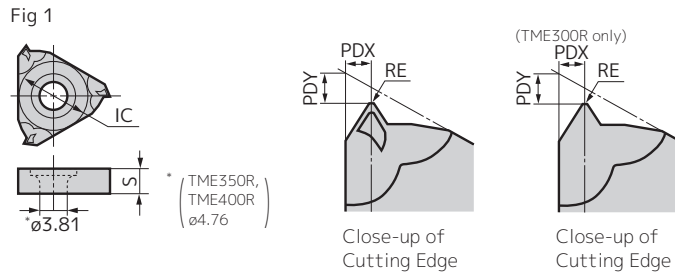

Inserts (Cermet)

Dimensions (mm)

Type	Cat. No.	Reference Cat. No.	Pitch		T1500A	Corner Radius RE	X Direction PDX	Y Direction PDY	Inscribed Circle IC	Thickness S	Wiper Edge	Applicable Holder	Fig
			mm	Threads/Inch									
60° Metric Thread	TME 100R	16ER100ISO-TE	1.00	—	●	0.11	0.8	1.2	9.525	3.65	Yes	LTE R2020 LTE R2525	1
	125R	16ER125ISO-TE	1.25	—	●	0.15	0.8	1.2	9.525	3.65	Yes		1
	150R	16ER150ISO-TE	1.50	—	●	0.19	1.0	1.2	9.525	3.65	Yes		1
	175R	16ER175ISO-TE	1.75	—	●	0.22	1.2	1.2	9.525	3.65	Yes		1
	200R	16ER200ISO-TE	2.00	—	●	0.26	1.4	1.2	9.525	3.65	Yes		1
	250R	16ER250ISO-TE	2.50	—	●	0.33	1.4	1.2	9.525	3.65	Yes		1
	300R	16ER300ISO-TE	3.00	—	●	0.40	1.8	1.2	9.525	3.65	Yes	1	
	TME 350R	22ER350ISO-TE	3.50	—	●	0.47	2.5	1.7	12.70	4.60	Yes	LTE R2525M22	1
400R	22ER400ISO-TE	4.00	—	●	0.54	2.5	1.7	12.70	4.60	Yes	LTE R3232P22	1	
55° Whitworth Thread	TME 1020R	16ER102060-TE	1.00 to 2.00	24 to 12	●	0.11	1.1	1.2	9.525	3.65	No	LTE R2020 LTE R2525	1
	1530R	16ER153060-TE	1.50 to 3.00	16 to 8	●	0.19	1.6	1.0	9.525	3.65	No		1
	TWE 1410R	16ER141055-TE	—	14 to 10	●	0.21	1.4	1.2	9.525	3.65	No		1
	2416R	16ER241655-TE	—	24 to 16	●	0.11	1.1	1.2	9.525	3.65	No		1
	TUE 24R	16ER24UN-TE	—	24	●	0.12	0.8	1.2	9.525	3.65	Yes		1
	20R	16ER20UN-TE	—	20	●	0.15	0.8	1.2	9.525	3.65	Yes		1
	18R	16ER18UN-TE	—	18	●	0.17	1.0	1.2	9.525	3.65	Yes		1
	16R	16ER16UN-TE	—	16	●	0.20	1.2	1.2	9.525	3.65	Yes		1
60° Unified Thread	14R	16ER14UN-TE	—	14	●	0.23	1.2	1.2	9.525	3.65	Yes	1	
	12R	16ER12UN-TE	—	12	●	0.28	1.4	1.2	9.525	3.65	Yes	1	
	08R	16ER08UN-TE	—	8	●	0.43	1.8	1.2	9.525	3.65	Yes	1	
	TPE 28R	16ER28BSPT-TE	—	28	●	0.09	0.9	0.7	9.525	3.65	Yes	1	
	19R	16ER19BSPT-TE	—	19	●	0.15	0.9	0.7	9.525	3.65	Yes	1	
	14R	16ER14BSPT-TE	—	14	●	0.22	1.6	1.2	9.525	3.65	Yes	1	
55° Taper Thread for Pipe	11R	16ER11BSPT-TE	—	11	●	0.29	1.6	1.2	9.525	3.65	Yes	1	

For these inserts, only LTE/STE type holders can be used.

SEC-External Threading Tool Holders STE series



External Turning
Screw-on / Lever Lock

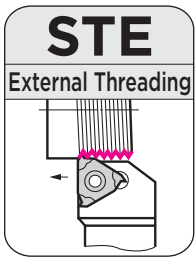
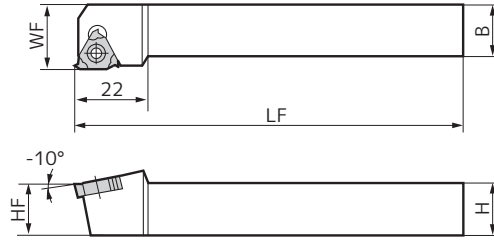

Fig 1



- M** Metric Thread
- W** Whitworth Thread
- UNC/UNF** Unified Thread
- R/Rc** Taper Thread for Pipe

Holder

Cat. No.	Stock	Height H	Width B	Overall Length LF	Cutting Edge Distance WF	Cutting Edge Height HF	Fig	Parts		
								Flat Head Screw	Wrench	Dimensions (mm)
STE R1212	●	12	12	100	16	12	1			
R1616	●	16	16	100	20	16	1	BFTX03508	2.0	TRX10

Fig 1

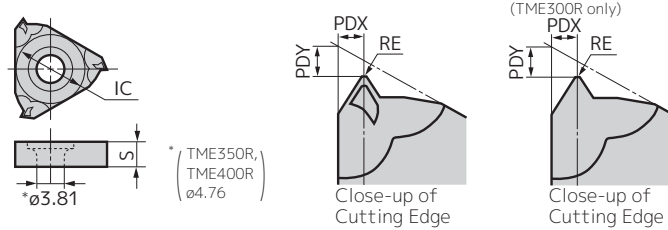

Inserts (Cermet)

Type	Cat. No.	Reference Cat. No.	Pitch		T1500A	Corner Radius RE	X Direction PDX	Y Direction PDY	Inscribed Circle IC	Thickness S	Wiper Edge	Applicable Holder	Fig
			mm	Threads/Inch									
60° Metric Thread	TME 100R	16ER100ISO-TE	1.00	—	●	0.11	0.8	1.2	9.525	3.65	Yes	STE R1212 STE R1616	1
	125R	16ER125ISO-TE	1.25	—	●	0.15	0.8	1.2	9.525	3.65	Yes		1
	150R	16ER150ISO-TE	1.50	—	●	0.19	1.0	1.2	9.525	3.65	Yes		1
	175R	16ER175ISO-TE	1.75	—	●	0.22	1.2	1.2	9.525	3.65	Yes		1
	200R	16ER200ISO-TE	2.00	—	●	0.26	1.4	1.2	9.525	3.65	Yes		1
	250R	16ER250ISO-TE	2.50	—	●	0.33	1.4	1.2	9.525	3.65	Yes		1
	300R	16ER300ISO-TE	3.00	—	●	0.40	1.8	1.2	9.525	3.65	Yes		1
60° Metric Thread	TME 1020R	16ER102060-TE	1.00 to 2.00	24 to 12	●	0.11	1.1	1.2	9.525	3.65	No		1
	1530R	16ER153060-TE	1.50 to 3.00	16 to 8	●	0.19	1.6	1.0	9.525	3.65	No		1
55° Whitworth Thread	TWE 1410R	16ER141055-TE	—	14 to 10	●	0.21	1.4	1.2	9.525	3.65	No		1
	2416R	16ER241655-TE	—	24 to 16	●	0.11	1.1	1.2	9.525	3.65	No		1
60° Unified Thread	TUE 24R	16ER24UN-TE	—	24	●	0.12	0.8	1.2	9.525	3.65	Yes		1
	20R	16ER20UN-TE	—	20	●	0.15	0.8	1.2	9.525	3.65	Yes		1
	18R	16ER18UN-TE	—	18	●	0.17	1.0	1.2	9.525	3.65	Yes		1
	16R	16ER16UN-TE	—	16	●	0.20	1.2	1.2	9.525	3.65	Yes	1	
	14R	16ER14UN-TE	—	14	●	0.23	1.2	1.2	9.525	3.65	Yes	1	
	12R	16ER12UN-TE	—	12	●	0.28	1.4	1.2	9.525	3.65	Yes	1	
	08R	16ER08UN-TE	—	8	●	0.43	1.8	1.2	9.525	3.65	Yes	1	
55° Taper Thread for Pipe	TPE 28R	16ER28BSPT-TE	—	28	●	0.09	0.9	0.7	9.525	3.65	Yes	1	
	19R	16ER19BSPT-TE	—	19	●	0.15	0.9	0.7	9.525	3.65	Yes	1	
	14R	16ER14BSPT-TE	—	14	●	0.22	1.6	1.2	9.525	3.65	Yes	1	
	11R	16ER11BSPT-TE	—	11	●	0.29	1.6	1.2	9.525	3.65	Yes	1	

For these inserts, only LTE/STE type holders can be used.

SEC-Threading Tools

THE series

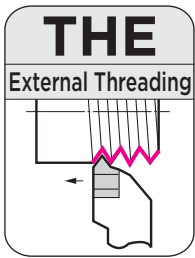
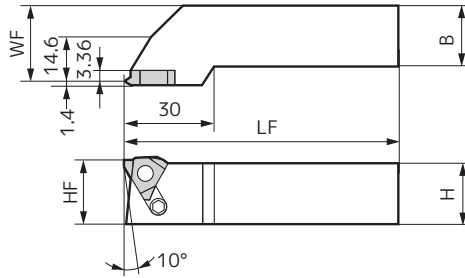

Fig 1



External Turning
Screw-on / Drawing Pin

- M** Metric Thread
- W** Whitworth Thread
- R/Rc** Taper Thread for Pipe

Threading Tools

T

Grooving

Cut-off

Threading

External Turning

Facing

Internal Turning

Necking

CBN

Holder

Cat. No.	Stock	Height	Width	Overall Length	Cutting Edge Distance	Cutting Edge Height	Fig
		H	B	LF	WF	HF	
THE R-33	●	20	20	125	25.0	20	1
R-44	●	25	25	150	32.2	25	1

Parts

Dimensions (mm)

Drawing Pin	Set Screw	Wrench
SR124	BTD0510	LH025

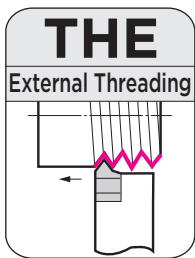
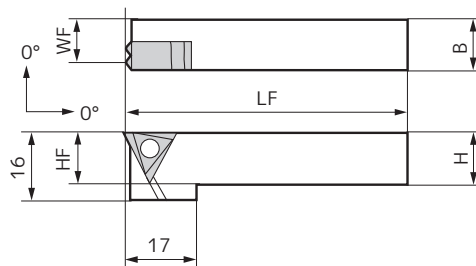

Fig 1



Screw-on / Drawing Pin for SEC-External Diameter (Mini Holders)

- M** Metric Thread
- W** Whitworth Thread
- R/Rc** Taper Thread for Pipe

Sumi Small

Holder

Cat. No.	Stock	Height	Width	Overall Length	Cutting Edge Distance	Cutting Edge Height	Fig
		H	B	LF	WF	HF	
THE R1010-33	●	10	10	100	8.6	10	1
R1212-33	●	12	12	100	10.6	12	1

Parts

Dimensions (mm)

Flat Head Screw	Wrench
BFX0410R	TH025

Inserts (Cermet / Cemented Carbide)

Dimensions (mm)

Cat. No.	T1500A	ST10P	A30	Pitch		Corner Radius	Included Angle	Cutting Edge Design	Applicable Holder
				mm	Threads/Inch				
				RE	PNA				
NE R080	●	●	●	0.80	—	0.08	60	A	THE R-33 THE R-44 THE R1010-33 THE R1212-33
R100	●	●	●	1.00	—	0.11	60	A	
R125	●	●	●	1.25	—	0.15	60	B	
R150	●	●	●	1.50	—	0.18	60	B	
R175	●	●	●	1.75	—	0.22	60	B	
R200	●	●	●	2.00	—	0.25	60	B	
R250	●	●	●	2.50	—	0.33	60	B	
R0815	●	●	●	0.80 to 1.50	—	0.08	60	C	
R1530	●	●	●	1.50 to 3.00	—	0.18	60	C	
WE R1410	●			—	14 to 10	0.21	55	C	
R2416	●			—	24 to 16	0.11	55	C	
PTE R28				—	28	0.09	55	D	
R19				—	19	0.15	55	D	

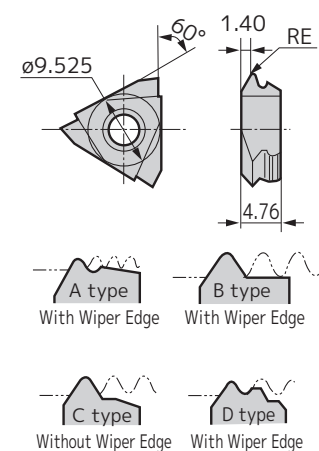

Internal Threading Tools STI series



Internal Threading
Screw-on

M Metric Thread
UNC/UNF Unified Thread

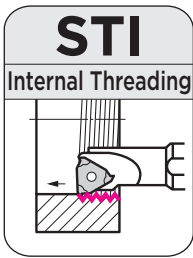
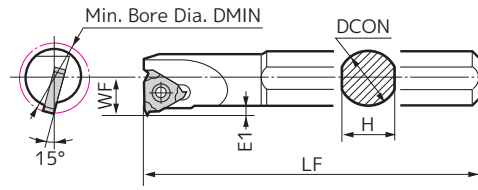

Fig 1



Holder

Parts

Dimensions (mm)

Cat. No.	Stock	Diameter DCON	Height H	Overall Length LF	Cutting Edge Distance WF	Cutting Edge Distance E1	Min. Bore Dia. DMIN	Fig	Flat Head Screw		Wrench
										N·m	
STI R316	●	16	15	150	11	3.5	20	1	BFTX03508	2.0	TRX10
R320	●	20	18	180	14	5.0	25	1			

Inserts (Cermet)

Dimensions (mm)

Cat. No.	Reference Cat. No.	Pitch		T1500A	Corner Radius RE	Included Angle PNA	X Direction PDX	Y Direction PDY	Fig	Fig 1
		mm	Threads/Inch							
TMI 100R	16IR100ISO-TI	1.00	—	●	0.04	60	0.8	1.2	1	
125R	16IR125ISO-TI	1.25	—	●	0.05	60	0.8	1.2	1	
150R	16IR150ISO-TI	1.50	—	●	0.07	60	1.0	1.2	1	
175R	16IR175ISO-TI	1.75	—	●	0.09	60	1.2	1.2	1	
200R	16IR200ISO-TI	2.00	—	●	0.10	60	1.4	1.2	1	
250R	16IR250ISO-TI	2.50	—	●	0.14	60	1.4	1.2	1	
300R	16IR300ISO-TI	3.00	—	●	0.18	60	1.8	1.2	1	
TMI 1020R	16IR102060-TI	1.00 to 2.00	24 to 12	●	0.04	60	1.0	1.2	1	
1530R	16IR153060-TI	1.50 to 3.00	16 to 8	●	0.07	60	1.5	1.2	1	

For these inserts, only STI type holders can be used.

Threading
Tools

T

Grooving

Cut-off

Threading

External
Turning

Facing

Internal
Turning

Necking

CBN



Internal Threading
Screw-on

M Metric Thread



Threading Tools

T

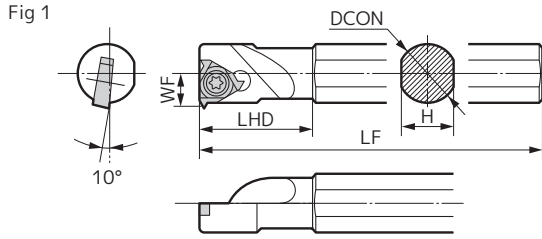
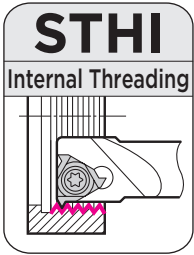

Holder

Parts Dimensions (mm)

Cat. No.	Stock	Diameter DCON	Height H	Overall Length LF	Cutting Edge Distance WF	Head LHD	Min. Bore Dia.	Applicable Insert	Fig	Parts	
										Flat Head Screw	Wrench
STHI 06	●	6	5.5	100	3.8	13.0	8.0	TI R06	1	BFTX0204NS	RT06
08	●	8	7.0	125	4.7	17.0	10.0	TI R08	1	BFTX0205NS	
10	●	10	9.0	150	6.0	20.0	12.0	TI R09	1	BFTX02206NT	

Insert (Coated Carbide)

Dimensions (mm)

Cat. No.	Reference Cat. No.	ACZ150	Pitch (mm)	Corner Radius RE	Inscribed Circle IC	Thickness S	Cutting Edge Distance E1	Maximum Depth of Cut CDX	Applicable Holder	Fig	Fig 1	
											E1: Cutting Edge Distance	CDX: Maximum Depth of Cut
TI R06	06IRO41060-HI	●	0.4 to 0.5 to 1.0	0.03	3.97	1.59	0.7	0.5	STHI06	1		
R08	08IRO41060-HI	●	0.4 to 0.5 to 1.0	0.03	4.76	2.38	0.7	0.5	STHI08	1		
R09	09IRO41060-HI	●	0.4 to 0.5 to 1.0	0.03	5.56	2.38	0.7	0.5	STHI10	1		

- For these inserts, only STHI type holders can be used.
- Recommended pitch is 0.5mm.

Recommended Cutting Conditions A24

External Turning

Facing

Internal Turning

Necking

CBN



Internal Threading
Clamp-on

M Metric Thread

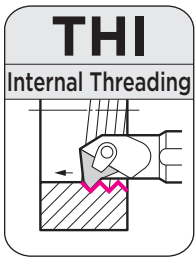
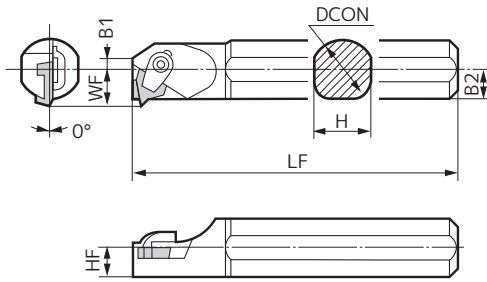

Fig 1



Holder

Parts

Dimensions (mm)

Cat. No.	Stock	Diameter DCON	Height H	Overall Length LF	Cutting Edge Distance WF	Cutting Edge Height HF	Width B1	Width B2	Min. Pilot Hole Diameter	Applicable Insert	Fig	Parts		
												Clamp Plate	Double Screw	Wrench
THI R216	●	16	15	160	9.3	7.5	4	7.5	∅18	NI R2000	1			
R320	●	20	18	160	11.7	9.0	6	9.0	∅22	NI R3000	1			
R325	●	25	23	180	14.2	11.5	5	11.5	∅27	NI R3000	1			

Inserts (□Cemented Carbide)

Dimensions (mm)

Cat. No.	ST10P	Pitch (mm)	Inscribed Circle IC	Thickness S	X Direction PDX	Corner Radius RE	Main Blade Relief Angle AN	Cutting edge design	Applicable Holder	Fig	Fig 1
NI R2000	●	0.8 to 1.5	6.350	3.18	0.85	0.05	12	C	THI R216	1	<p>B type With Wiper Edge</p> <p>C type Without Wiper Edge</p>
R2150	●	1.5	6.350	3.18	0.85	0.07	12	B	THI R216	1	
NI R3000	●	0.8 to 2.5	9.525	3.18	1.35	0.05	10	C	THI R320	1	
R3150	●	1.5	9.525	3.18	0.85	0.07	10	B	THI R320	1	
R3200	●	2.0	9.525	3.18	1.10	0.11	10	B	THI R325	1	

- The cutting edge honing of the inserts can be enlarged for threading at a pitch of 1.5mm or more with the NIR2000 and a pitch of 2.5mm or more with the NIR3000. The honing amount must be within the threading tolerance.
- Inserts use 3 corners.

Guide to Depth of Cut and No. of Passes

Threading Tool Depth of Cut Guide

■ With Wiper Edge

Application	Cat. No.	Reference Cat. No.	Pitch	Depth of Cut	No. of Passes	1	2	3	4	5	6	7	8	9	10	11	12	13	14		
60° Metric Thread	External Threading																				
	TME 100R	16ER 100ISO-TE	1.00mm	0.68	5	0.20	0.16	0.14	0.11	0.07											
	TME 125R	16ER 125ISO-TE	1.25	0.83	6	0.20	0.18	0.15	0.12	0.11	0.07										
	TME 150R	16ER 150ISO-TE	1.50	0.96	7	0.22	0.18	0.14	0.13	0.12	0.10	0.07									
	TME 175R	16ER 175ISO-TE	1.75	1.12	8	0.22	0.19	0.16	0.14	0.13	0.12	0.09	0.07								
	TME 200R	16ER 200ISO-TE	2.00	1.25	8	0.25	0.21	0.18	0.16	0.15	0.13	0.10	0.07								
	TME 250R	16ER 250ISO-TE	2.50	1.55	10	0.27	0.24	0.20	0.18	0.16	0.13	0.11	0.10	0.09	0.07						
	TME 300R	16ER 300ISO-TE	3.00	1.85	12	0.28	0.25	0.20	0.19	0.17	0.15	0.13	0.12	0.10	0.10	0.09	0.07				
	TME 350R	22ER 350ISO-TE	3.50	2.25	13	0.30	0.27	0.24	0.22	0.20	0.18	0.16	0.15	0.14	0.12	0.11	0.09	0.07			
	TME 400R	22ER 400ISO-TE	4.00	2.57	14	0.35	0.32	0.29	0.26	0.23	0.20	0.17	0.15	0.14	0.12	0.10	0.09	0.08	0.07		
	Internal Threading																				
	TMI 100R	16IR 100ISO-TI	1.00mm	0.63	5	0.18	0.16	0.12	0.10	0.07											
	TMI 125R	16IR 125ISO-TI	1.25	0.77	6	0.18	0.16	0.14	0.12	0.10	0.07										
	TMI 150R	16IR 150ISO-TI	1.50	0.90	7	0.20	0.16	0.14	0.13	0.11	0.09	0.07									
	TMI 175R	16IR 175ISO-TI	1.75	1.03	8	0.20	0.18	0.15	0.14	0.11	0.10	0.08	0.07								
	TMI 200R	16IR 200ISO-TI	2.00	1.18	8	0.22	0.19	0.17	0.15	0.14	0.13	0.11	0.07								
	TMI 250R	16IR 250ISO-TI	2.50	1.44	10	0.25	0.22	0.19	0.16	0.14	0.12	0.10	0.10	0.09	0.07						
	TMI 300R	16IR 300ISO-TI	3.00	1.70	12	0.27	0.24	0.20	0.17	0.14	0.12	0.12	0.10	0.10	0.09	0.08	0.07				
60° Unified Thread																					
External Threading																					
TUE 24R	16ER 24UN-TE	24TPI	0.72	5	0.20	0.18	0.15	0.12	0.07												
TUE 20R	16ER 20UN-TE	20	0.85	6	0.21	0.18	0.16	0.13	0.10	0.07											
TUE 18R	16ER 18UN-TE	18	0.95	6	0.22	0.20	0.18	0.16	0.12	0.07											
TUE 16R	16ER 16UN-TE	16	1.05	7	0.22	0.20	0.17	0.15	0.13	0.11	0.07										
TUE 14R	16ER 14UN-TE	14	1.20	8	0.22	0.20	0.18	0.16	0.14	0.12	0.11	0.07									
TUE 12R	16ER 12UN-TE	12	1.38	9	0.25	0.22	0.19	0.17	0.15	0.13	0.11	0.09	0.07								
TUE 08R	16ER 08UN-TE	8	2.05	12	0.28	0.25	0.23	0.21	0.19	0.17	0.15	0.14	0.13	0.12	0.11	0.07					
55° Taper Thread for Pipe																					
External Threading																					
TPE 28R	16ER 28BSPT-TE	28TPI	0.62	5	0.18	0.15	0.13	0.10	0.06												
TPE 19R	16ER 19BSPT-TE	19	0.92	6	0.22	0.20	0.17	0.15	0.11	0.07											
TPE 14R	16ER 14BSPT-TE	14	1.04	7	0.22	0.20	0.17	0.15	0.13	0.10	0.07										
TPE 11R	16ER 11BSPT-TE	11	1.50	9	0.25	0.22	0.21	0.19	0.17	0.15	0.13	0.11	0.07								

*When pitch becomes smaller, decrease the cutting speed. In the case of inserts for internal threading without wiper edge, the number of passes should be increased.

■ Recommended Cutting Speeds

(Units: m/min)

Work Material	Tool Grade		
	T1500A / T130A	A30	ST10P
P Mild Steel	100 - 150	70 - 120	120 - 180
P Low-carbon Steel	80 - 130	70 - 100	90 - 150
P Alloy Steel	80 - 120	70 - 100	80 - 130
M Stainless Steel	—	70 - 100	—

